

CHERM NOTE

TE

PREPARED BY DILLIRAJ PANGENI
COMPUTER ENGINEERING

Unit: 1

Introduction to Electronic Devices

1.1. Describe matter, molecule and atom Matter

Any substances, such as a solid, liquid or gas that has weight (mass) and occupies space are called as matter. For anything to occupy space, it must have volume. Based on this, we can say that everything on earth that has weight and takes up some space can be called as matters. Ultimately, everything on earth is matter. Examples of matter are: copper, iron, table, book, Ice, Vapour etc.

Types of matter:

- a) Solid
- b) Liquid
- c) Gas.

a) Solid:

The hard substances that we see around us are solids. They are hard because of their molecules are packed in very high density. Examples include book, pen, apple, a piece of wood, plastic etc. They are all solids at room temperature. They can exist in different sizes, shapes and forms.

Think of ice cubes as an example. They are solids when frozen. They change into liquid when temperature is above zero degree.

b) Liquid:

The particles in liquids are not as closely bonded, arranged and fixed in place as in solids. The particles in liquid can flow freely and can mix with particles from other liquids. Liquids have their atoms close together, so they are not very easy to compress.

c) Gas:

Gas is everywhere, and it is around us. The air around us is a kind of gas. The atmosphere surrounding the earth is a gas too. Helium, Oxygen, Carbon dioxide and water vapor are all examples of gas.

Molecule

A group of two or more than two atoms of the same or different elements that are chemically bonded together.

Examples of molecule are: O₂, H₂O etc.

Atom

Atom is the smallest particle of an element. Atoms are made up of electrons, neutrons and protons.

Examples of atoms are: Hydrogen (H), Iron (Fe) etc.

1.2. Introduction of KCL, KVL:

Kirchhoff's Current Law

According to Kirchhoff's Current Law,

The total current entering a junction or a node is equal to the charge leaving the node as no charge is lost.

In other words the algebraic sum of ALL the currents entering and leaving a node must be equal to zero, $I(\text{exiting}) + I(\text{entering}) = 0$.

Current entering the node will be positive and current leaving the node will be negative.

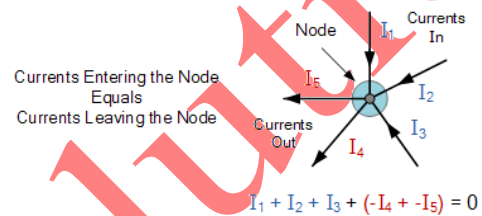

Kirchhoff's Voltage Law

Kirchhoff's voltage law states that the voltage around a loop equals the sum of every voltage drop in the same loop for any closed network and equals zero.

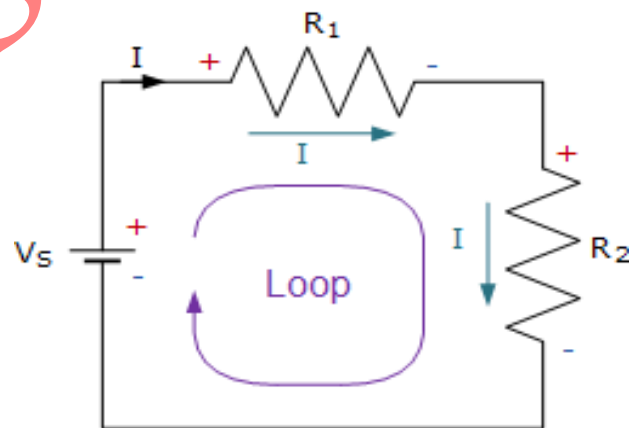

By kvl in the following circuit. $V_s + (-IR_1) + (-IR_2) = 0$

1.3. Introduction to Semiconductor material:

The material which has electrical conductivity between that of a conductor and an insulator is called as semiconductor. Silicon, germanium and graphite are some examples of semiconductors.

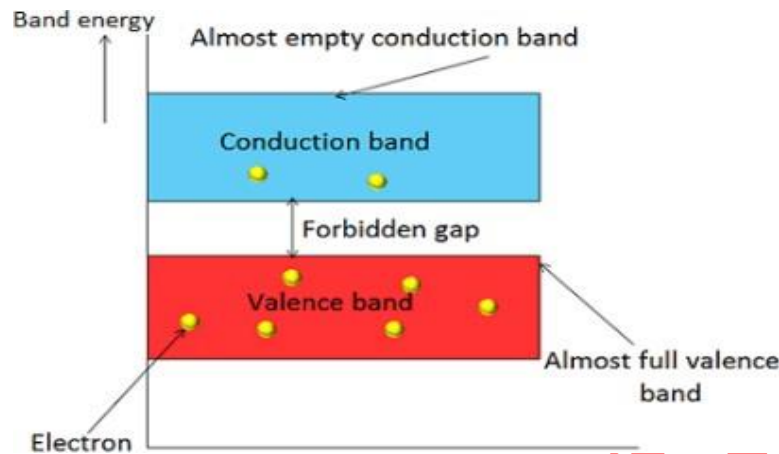

In semiconductors, the forbidden gap between valence band and conduction band is very small. It has a forbidden gap of about 1 electron volt (eV). At low temperature, the valence band is completely occupied with electrons and conduction band is empty because the electron in the valence band does not have enough energy to move in to conduction band. Therefore, semiconductor behaves as an insulator at low temperature. However, at room temperature some of the electrons in valence band gains enough energy in the form of heat and moves in to conduction band.

There are two types of semiconductor.

- a) Intrinsic semiconductor
- b) Extrinsic semiconductor

Intrinsic semiconductor :

A semiconductor where there is no any impurity is doped is called intrinsic semiconductor. It is pure semiconductor .It has poor conductivity of electricity. Example of intrinsic semiconductor is silicon(si), Germanium(ge) etc. It is form by the tetravalent (having four valence electron) elements.

At 0 degree temperature there is no any free electron when at room temperature(25⁰) covalent bond is broken and free electron is form. Electron move in particular direction and current is produce.

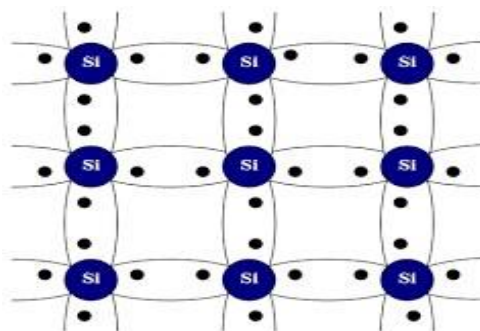

Intrinsic semiconductor structure

Extrinsic Semiconductor

A semiconductor where impurity is added into pure semiconductor then form extrinsic semiconductor. It has good conductivity. It is two types. They are :

- I) N- type
- II) P-type

i) N- type :

When pentavalent (having 5 valence electron) impurity atom such as antimony, phosphorous is added to pure semiconductor (Si, Ge) then N type semiconductor is formed. In figure four electron makes bond and one electron is free which produce current. Majority charge carrier is free electron.

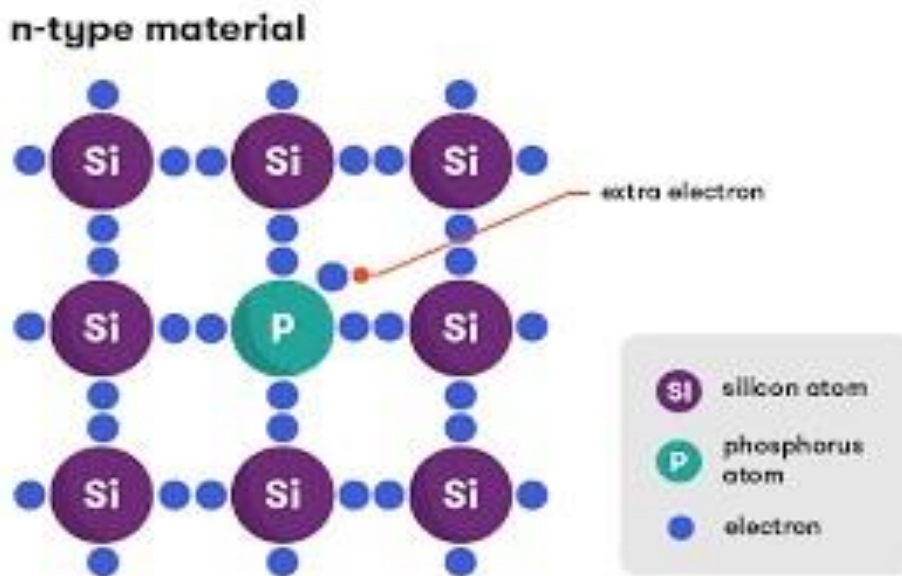

i) P-type :

A p-type semiconductor is an intrinsic semiconductor doped with trivalent(having three valence electron) impurity atoms . when trivalent impurity(Boron,Almunium) added with silicon & germanium then form p type semiconductor. Look at given figure ,

Trivalent impurity atom is added with Germanium. There is one electron is less that cannot make bond that create holes. When electric field is applied then electron goes to fill the hole.Again there is another hole is create then other electron comes to fill this hole. This process is continuously happen. Due to this process electron are moving and current is flow. In it holes are majority carrier.

Class 10 Computer Hardware , Electronics , repair and maintenance

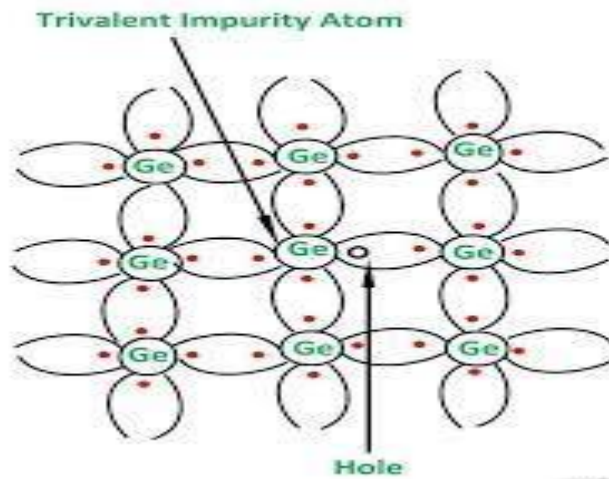

P-Type semiconductor structure

ION

Intrinsic Semiconductors	Extrinsic Semiconductors
Semiconductor in its purest form.	Semiconductor in its impure form.
It has low conductivity.	It has a higher conductivity than an intrinsic semiconductor
The band gap between the conduction and valence bands is quite narrow.	The energy gap is greater than that of an intrinsic semiconductor.
Fermi level can be found in the forbidden energy gap.	The presence of a Fermi level depends on the type of extrinsic semiconductor.
Temperature alone determines electrical conductivity.	Electrical conductivity in a pure semiconductor is affected by temperature as well as the quantity of impurity doping.
Pure Silicon and Germanium crystalline forms are examples.	Impurities such as As, Sb, P, In, Bi, Al, and others are doped with Germanium and Silicon atoms.

Difference between P type and N type semiconductor

P type	N type
It is acceptor type	It is donor type
Impurity atom is trivalent.	Impurity atom is pentavalent
Holes are majority carrier.	Electrons are majority carrier
Also known as trivalent semiconductor.	Also known as pentavalent semiconductor.
Holes are generated	Electron are generated.
Electrons are minority carrier.	Holes are minority carrier.

Doping:

One way to increase conductivity of a semiconductor is by doping. This means adding impurity atoms to an intrinsic crystal to alter its electrical conductivity. A doped semiconductor is called an extrinsic semiconductor. To increase the conductivity of the semiconductor, doping is done.

Majority and minority charge carriers definition

The charge carriers that are present in large quantity are called majority charge carriers. The majority charge carriers carry most of the electric charge or electric current in the semiconductor. Hence, majority charge carriers are mainly responsible for electric current flow in the semiconductor. The charge carriers that are present in small quantity are called minority charge carriers. The minority charge carriers carry very small amount of electric charge or electric current in the semiconductor.

1.4 PN junction formation , forward biased and reverse biased

When an n-type semiconductor is joined with the p-type semiconductor, a p-n junction is formed. The region where the p-type and n-type semiconductors are joined is called p-n junction. It is also defined as the boundary between ptype and n-type semiconductor. This p-n junction forms a most popular semiconductor device known as diode. Diode is used for as rectifier in electronic circuits.

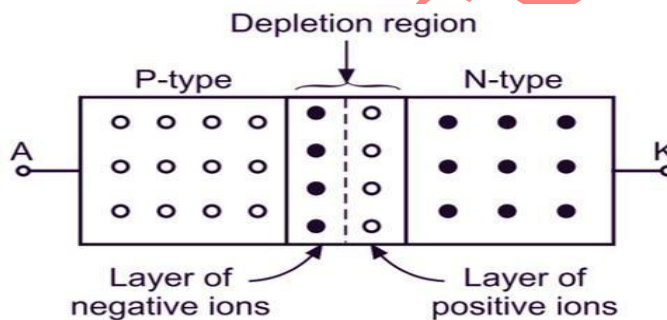
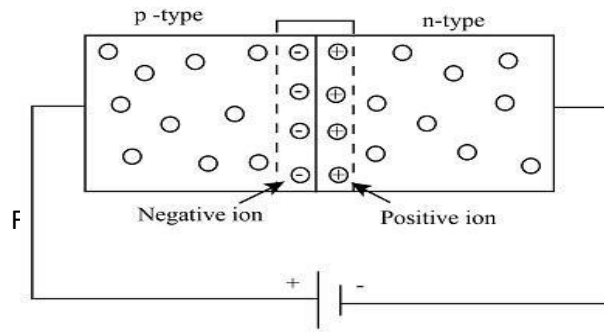

Fig: PN Junction formation

P-n junction is also a fundamental building block of many other semiconductor electronic devices such as transistors, solar cells, light emitting diodes, and integrated circuits.

Forward Biased

When V is applied to the PN junction diode from the outside. Connect the P types to the positive terminal and the N type to the negative terminal. Holes in the P-type region and electrons in the N-type region are pushed towards the junction. This will reduce the width of the shrink zone. A PN junction then said to be forward biased.



Reverse Biased

When a diode is connected in a Reverse Bias condition, a positive terminal of voltage is applied to the N-type material and a negative terminal of voltage is applied to the P-type material.

The positive voltage applied to the N-type material attracts electrons towards the positive terminal of dc source and away from the junction, while the holes in the P-type end are also attracted towards the negative terminal of dc source away from the junction.

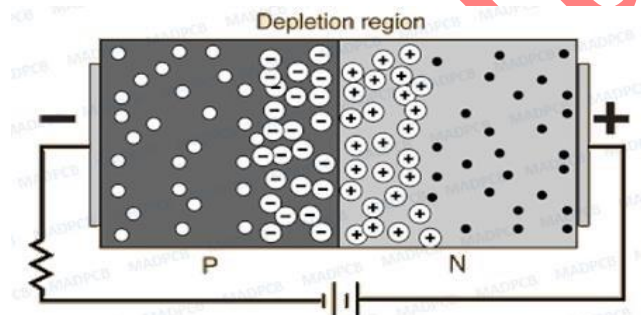

Unit: 2

2.1 Introduction to Basic Components of Computer System

Computer systems consist of three components as shown in below image: **Central Processing Unit, Input devices and Output devices**. Input devices provide data input to processor, which processes data and generates useful information that's displayed to the user through output devices. This is stored in computer's memory.

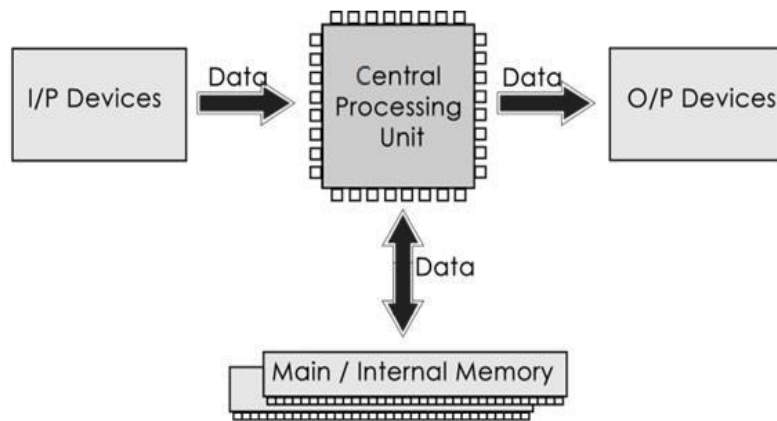

2.2 Input Unit: Keyboard, Mouse, Scanner and Digital Camera

Input Unit:

Input unit provides an interface between user and machine, for inputting data and instruction into the computer memory. Input unit accepts input, converts it into computer readable format and provides it for processing and storage.

Input Devices:

The devices that are used to enter data and instructions or commands into the computer are called input devices. The input devices can be considered as the eyes and ears of computers. The most popular input devices are as follows:

A) Keyboard:

The keyboard is the most commonly used input device in the personal computer. It is used to feed data and instructions into a computer. A keyboard contains keys for each alphabetic characters, numbers, special characters and some additional keys for specific functions. The data and instructions are feed into the computer by pressing the related keys on the keyboard.

Class 10 Computer Hardware , Electronics , repair and maintenance

B) Mouse:

The mouse is the most commonly used pointing input device in the personal computer. It is used to point object and give commands to the computer. When you move the mouse on the mouse pad, the mouse pointer on the screen moves in the corresponding direction.

C) Scanner:

A scanner is an input device that optically scans images, printed text, handwriting, or an object and converts it to a digital and then sends to the computer.

D) Digital Camera:

A digital camera is a hardware device that takes photographs and stores the image as data on a memory card. A digital camera is a camera that produces digital images that can be stored on a computer, displayed on a screen, and printed.

2.3 Introduction to processing unit: ALU & Control Unit

The part of a computer that performs logical and arithmetical operations on the data as specified in the instructions. A central processing unit (CPU), also called a central processor, main processor or just processor, is the electronic circuitry that executes instructions comprising a computer program. The CPU performs basic arithmetic, logic, controlling, and input/output (I/O) operations specified by the instructions in the program.

There are three segments of CPU are as follows:

1. Arithmetic-Logic Unit:

An arithmetic-logic unit is the part of a central processing unit that carries out arithmetic and logic operations on the operands in computer instruction words. In some processors, the ALU is divided into two units: an arithmetic unit (AU) and a logic unit (LU).

2. Control Unit:

The control unit (CU) is a component of a computer's central processing unit (CPU) that directs the operation of the processor. A CU typically uses a binary decoder to convert coded instructions into timing and control signals that direct the operation of the other units (memory, arithmetic logic unit and input and output devices, etc.).

3. Register:

A processor register (CPU register) is one of a small set of data holding places that are part of the computer processor. A register may hold an instruction, a storage address, or any kind of data (such as a bit sequence or individual characters).

Class 10 Computer Hardware , Electronics , repair and maintenance

2.4. Introduction to Display unit: Monitor Resolution, color and refresh rate, CRT, LCD and LED: Display Unit:

Display unit provides the result after processing the data to the users. It provides the output into user understandable format before providing it to the users. The output generated by the computer is of two types' hardcopy and softcopy. The result of processing is called output. Output devices receive the information from computer and provide them to the user. We can see the output on a screen, print it on the printer or hear it through speakers. The devices that are used to get output from the computer are called output devices.

Monitor:

The monitor is a popular and most commonly used output device. The monitor consists of a screen and the electronic components that produce the output on the screen for a temporary period. It is also called Visual Display Unit (VDU) that provides visual display. The output received on the monitor screen is called softcopy output.

Monitor resolution

Monitor resolution describes the virtual dimensions of any given display. Expressed in terms of width and height, monitor resolution is comprised of a specific number of pixels.

Common Monitor Resolutions

1. HD (High Definition):

720p (1280 × 720): Often used in small monitors and budget laptops. It offers basic clarity but lacks the sharpness for detailed work or high-end gaming.

2. Full HD (FHD):

1080p (1920 × 1080): The standard for most monitors and TVs. It balances clarity and performance, making it suitable for gaming, video editing, and general use.

3. 2K:

1440p (2560 × 1440): Provides greater detail than 1080p, ideal for gamers and professionals who need higher resolution for better clarity and more screen real estate.

4. Ultra HD (UHD) or 4K:

2160p (3840 × 2160): Four times the resolution of 1080p, offering exceptional clarity. It's perfect for high-end gaming, professional video editing, and large displays.

5. 8K:

4320p (7680 × 4320): The cutting edge of display technology, providing unparalleled detail. Currently, it is more common in high-end TVs and specialized professional monitors due to its high cost and the need for powerful hardware to support it.

Monitor color

Most video cards have several different operating modes. Each mode has a different number of colors. For example, the most basic mode in windows is mode called "VGA" which has a resolution of 640 by 480 and 16 colors. This means that the display has 640 pixel horizontally, 480 pixel vertically and display no more than 16 colors at a one time. Other common resolution includes 800x600, 1024x768 and 1280x1024. Other color common modes include 256 colors, 65536 colors and 16 million colors.

Monitor refresh rate:

The refresh rate of a display is the number of times per second that the image refreshes on the screen. For example, a 60Hz display will update the screen 60 times per second.

Overall, the refresh rate determines how smoothly motion appears on your screen. For example, if you're playing a game that has a lot of fast-moving action, a higher refresh rate can help improve your overall gaming experience to keep up with the action.

How to change the refresh rate

1. Select the **Start** button, then select **Settings** > **System** > **Display** > **Advanced display settings**.
2. Under **Refresh rate**, select the rate you want.

The refresh rates that appear depend on your display and what it supports. Select laptops and external displays will support higher refresh rates.

CRT Monitor:

It stands for "Cathode Ray Tube", CRT is the technology used in traditional computer monitors and television.

The cathode ray tube (CRT) is a vacuum tube that contains one or more electronic guns and used to display images.

The image on a CRT display is created by firing electrons from the back of the tube to phosphorus located towards the front of the display. Once the electrons hit the phosphorus they light up and are projected on the screen. This color you can see in the screens produced by a blend of red, blue & green light.

How to CRT monitor works:

Electron generated at the cathode are accelerated and concentrated and hit the beam sieve. The screen is covered with fluorescent dots that emit light of a specific color when excited. The three phosphors used in the dots emit red, green and blue light when hit by an electron beam. Red ,green and blue are called primary color and all other color can be created by mixing these three colors in proper proportion . To create an image on the screen , an electron beam scans fluorescent dots according to information gleaned from the video signal. Fluorescent dots are illuminated anywhere on the screen to create the desired image with the appropriate color an intensity.

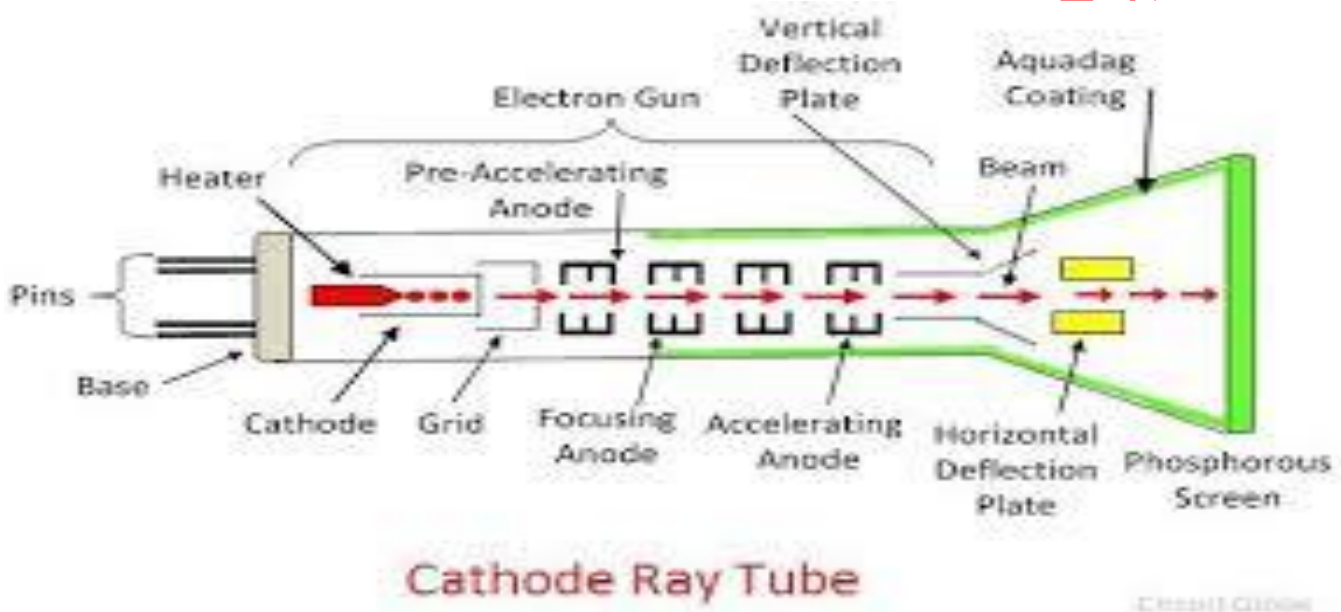

LCD Monitor:

The full form of LCD is Liquid Crystal Display. It uses special kind of liquid crystal to display video and graphics on the screen. It consumes very less power than CRT monitor. It is very lighter and more portable than the CRT monitor. The biggest advantage of LCD monitor is their size and weight. LCD screen also tends to produce less eye fatigues to the user. Another advantage of LCD screen is its fixed resolution.



LED Monitor:

The full form of LED is Light Emitting Diodes. LED is the advance application of LCD. It is better than the LCD technology. Due to the better techniques used in the LED monitors, these monitors are very accurate in their color display. The contrast ratio of LED monitors is much better than that of the LCD monitors. The viewing angle of LCD monitors is not flexible and the viewers are required to see the LCD monitors from an angle of 30 degrees. Any change in this viewing angle can diminish the quality of the picture to a greater extent.



CRT Monitor	LCD Monitor
It is less expensive.	It is more expensive.
It takes up more desk space.	Doesn't take up much space.
It uses more energy.	Are more energy efficient.
It is heavier and bulkier.	Weigh's much less.
It emits harmful radiation.	Doesn't emit radiation.
It is used only for PCs.	Also used for laptops, PDAs, cellular phones.

LED

VERSUS

LCD

LED	LCD
Contrast ratio is high	Contrast ratio is medium
Medium viewing angle	Low medium viewing angle
High price	Low price
Low power consumption	Medium power consumption
Faster response time	Slower response time
More color accuracy	Less color accuracy
Thinner	Thicker

Visit www.PEDIAA.com

Technotesonline

Unit: 3 Overview on System's Core

Introduction to system BIOS

BIOS stands for Basic Input/output System. It is firmware(program stored in ROM) used during the booting process of a computer and provides a low-level interface between the hardware and the operating system. It is found on motherboards that are a pre-installed program on Windows-based computers that executes when a computer is powered up. Before an OS is loaded, the CPU accesses the basic input/output system (BIOS). Then, the next function of BIOS is to examine all the hardware connections and detects all your devices. Mainly it is located on EPROM (erasable programmable read-only memory) chip.

In the early 21st century, BIOS was supplanted by United Extensible Firmware Interface (UEFI), which can handle much larger drives and operate faster than BIOS.

Users can perform different functions by using the BIOS user interface, which is discussed below:

- Users can perform hardware configuration
 - They can select boot drives
 - They can set the system clock
 - The BIOS allows users to enable and disable certain system components
 - To BIOS user interface function, it provides set password prompts for secured access

Function of BIOS

1. **Power-On Self-Test (POST):** BIOS performs a POST to check the computer's hardware components, such as the CPU, memory, and storage devices, ensuring they are functioning correctly.
2. **Boot Loader:** BIOS locates and executes the boot loader, a small program that loads the operating system into the computer's memory from the hard drive or another bootable device.
3. **Hardware Initialization:** BIOS initializes and configures hardware components, such as the keyboard, mouse, and display, to ensure they are ready for use.
4. **System Configuration:** BIOS provides a setup utility that allows users to configure hardware settings, such as the system clock, boot sequence, and hardware security settings.
5. **Firmware Interface:** BIOS provides a consistent interface between the operating system and the hardware, allowing the OS to interact with the computer's hardware components.

By performing these functions, the BIOS ensures that the computer's hardware is ready and correctly configured to boot and run the operating system.

Introduction to Motherboard:

A motherboard, often referred to as the mainboard, system board, or logic board, is the central printed circuit board (PCB) in many modern computers and electronic systems. It holds and allows communication between many of the crucial electronic components of a system, such as the central processing unit (CPU), memory, and connectors for input and output devices.

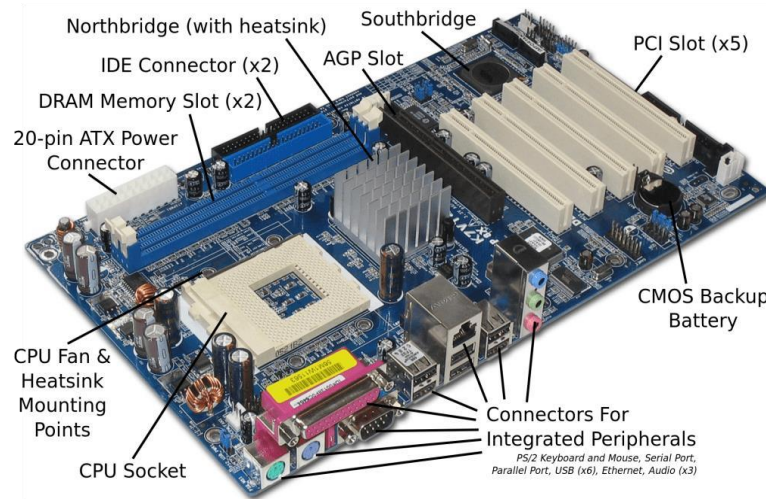

Features of motherboard

1. Motherboard vary greatly support to different types of components.
2. The motherboard supports a single types of CPU and some types of memory.
3. Video card, hard disk, sound card must be compatible with the motherboard to work properly.
4. Motherboard, cases and power supplies must be compatible to work together.

Motherboard form factor

The shape and general physical layout of a component is called form factor. the motherboard form factor indicates the shape and size specifications of the board. The form factor also determines additional parameters such as the casing, power supply, mounting holes, and overall physical layout. The first form factor dates back to 1983

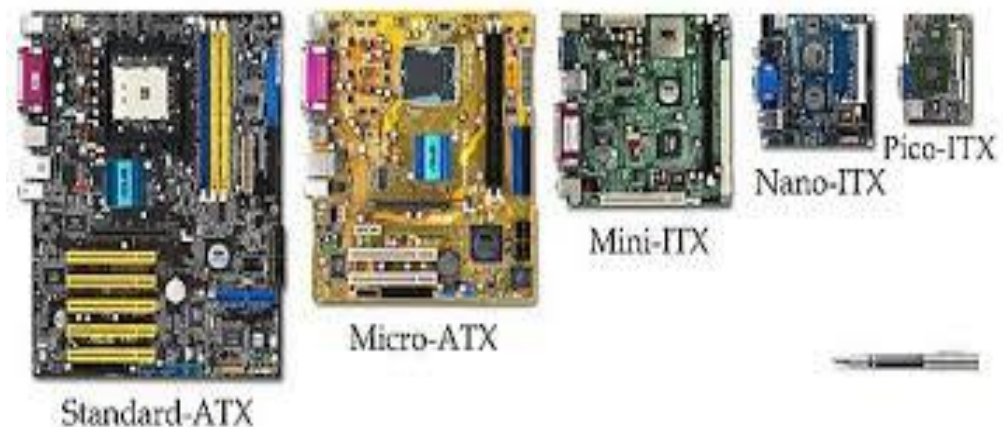

Class 10 Computer Hardware , Electronics , repair and maintenance

1. ATX:

ATX motherboards typically measure 30.5cm x 24.4cm(12 × 13 in.) and can fit inside mid or full tower cases. The extra size means this type of motherboard comes with multiple PCIe lanes allowing for **multi-GPU(Graphic processing unit) support**. for gamers and enthusiasts looking to take full advantage of the latest gaming hardware, ATX motherboards feature higher RAM capacity and are often better for extreme **overclocking**.

2. Micro ATX:

It is an evolution of ATX. Its measures are 9.6 × 9.6 inches. The Micro-ATX supports up to four expansion slots that can combine freely with ISA, PCI, PCI / ISA shared, and AGP. Mounting holes changed from the Standard ATX, since the measurements are different, but they are also compatible with most ATX cabinets.

This type of motherboard form factor supports both Intel and AMD processors. It is commonly used on Small Form Factor Desktop Computers.

3. Mini-ITX

Mini ITX is a low-power consumption motherboard format of 6.7 × 6.7 inches. It contain two PCIs . Although this type of motherboard was designed with the aim of empowering teams of low consumption, at present there are no limits and they have grown by giant steps in terms of benefits.

Mini ITX is a standard format for all types of equipment, such as vehicle embedded computers, industrial applications, and IoT.

4. Nano-ITX:

The Nano-ITX have only one PCIs, that measures 4.7 × 4.7 in. Nano-ITX are fully integrated boards designed to consume very low power. This type of motherboard can be used in many applications, but it was specially designed for smart entertainment, media centers, smart TVs, in-vehicle devices, and more.

5. Pico-ITX:

The Pico-ITX is the smallest type of motherboard form factor in this list. Its measurements are 3.9 × 2.8 in and it is 75% smaller than the Mini-ITX. There is single PCIs with very small size.

Brief comparison of motherboard form factor

Form Factor	Manufacturer/Date	Dimensions	Applications
Standard-ATX	Intel 1995	12 × 9.6in	Workstation/Desktop
Micro-ATX	Intel 1997	9.6 × 9.6 in	Small Form Factor
Mini-ITX	VIA 2001	6.7 × 6.7 in	Small Form Factor
Nano-ITX	VIA 2003	4.7 × 4.7 in	Embedded Systems
Pico-ITX	VIA 2007	3.9 × 2.8 in	Embedded Systems

Peripheral component interconnect (PCI) local bus

The Peripheral Component Interconnect (PCI) local bus is a computer bus standard designed to facilitate the connection of peripheral devices to a computer's motherboard. Introduced by Intel in 1992, PCI provides a highspeed interface that has become fundamental in the development of personal computers, workstations, and servers.

Features:

- PCI offers faster data transfer rates .
- PCI allows peripheral devices to communicate directly with each other without going through the CPU.
- PCI uses multiplexed address and data lines, which means fewer pins are needed on the connectors, reducing physical space and cost.
- PCI supports plug and play (PnP) capabilities, allowing devices to be automatically configured by the operating system.

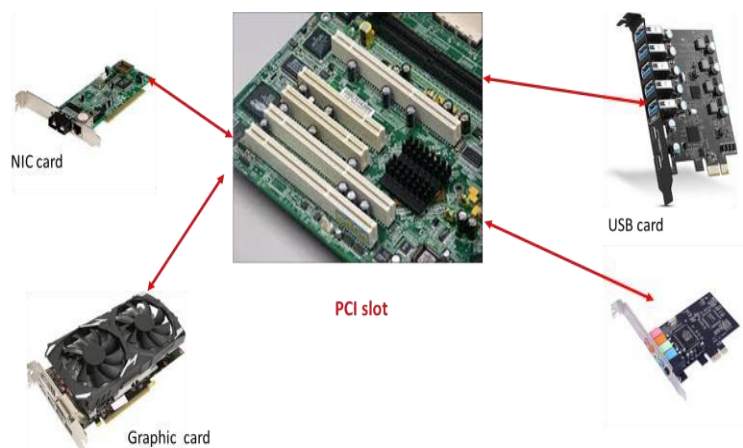

Types of PCI

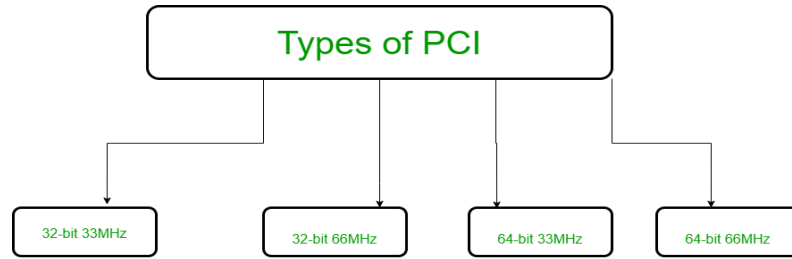

- PCI 32 bits have a transport speed of 33 MHz and work at 132 MBps.
- PCI 64 bits have a transport speed of 33 MHz and work at 264 MBps.
- PCI 32 bits have a transport speed of 66 MHz and work at 512 MBps.
- PCI 64 bits have a transport speed of 66 MHz and work at 1 GBps.

The internal Power supply

Power Supply is a hardware component that supplies power to an electrical device. It receives power from an electrical outlet and converts from AC to DC.

A power supply unit converts mains AC to low-voltage regulated DC power for the internal components of a computer. Modern personal computers universally use switched-mode power supplies. Some power supplies have a manual switch for selecting input voltage, while others automatically adapt to the mains voltage

There are different types of power supply. Some they are:

- SMPS : Switch Mode Power Supply
- UPS : Uninterruptible Power Supply
- AC to DC supply converter

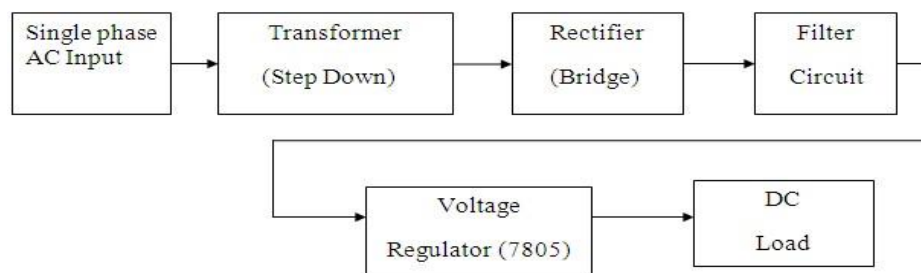

Block diagram of power supply unit

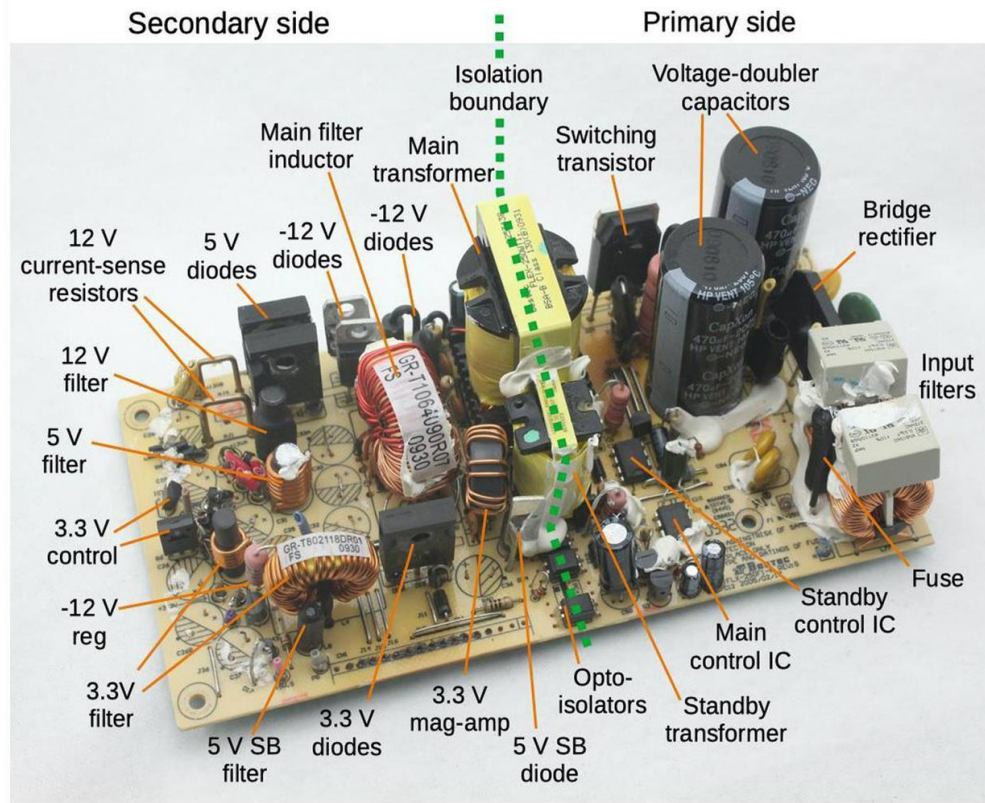

Parts of power supply

1. The Transformer

The transformer is used to step the AC voltage up and down. It transfers electrical energy between the primary winding and secondary winding, and it does so without changing the frequency. The transformer's primary winding connects to the AC voltage source, while the secondary one correlates to the load.

2. The Rectifier

The rectifier is responsible for changing AC power to pulsating DC power. The basic rectifier is a diode — that is, a unidirectional device operating as a rectifier in the forward direction. Rectifiers are employed in voltage multipliers, modulators and demodulators.

3. The Filter

The filter changes the pulsating DC produced by the rectifier to a smooth DC level. It suppresses ripple, which is the AC component in a signal following rectification. High ripples can damage the load. There are two main types of filters for power supplies: C-filters and RC-filters. C-filters are the simplest version of the two.

Class 10 Computer Hardware , Electronics , repair and maintenance

4. The Regulator Circuits

The voltage regulator helps ensure that the DC output voltage is stable regardless of any variation in the input voltage, which enables the load to operate properly. The most common types of regulators are the series voltage regulator and the shunt voltage regulator.

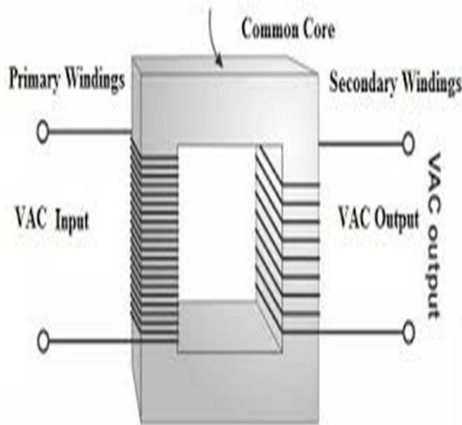

transformer



filter

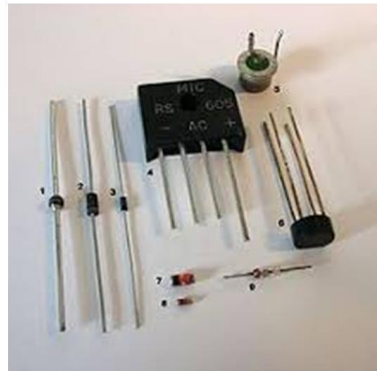

diode



Rectifier



capacitor

Introduction to Hard Drive

Hard disk is the most common secondary storage device in the personal computer. It is also called the magnetic disk, HDD, fixed drive, or fixed disk. It is the main and the largest data storage device in the computer. It can store a large amount of data and information permanently. The storage capacity of hard disk ranges from 100's Gigabyte (GB) to some Terabytes (TB) such as 200 GB, 300 GB, 500 GB, 1 TB, 2 TB, 4 TB, etc. The first hard drive was introduced by IBM in 1956.

Class 10 Computer Hardware , Electronics , repair and maintenance

Types of hard disk : Solid state disk (SSD, new hard disk), Mechanical Hard disk(magnetic disk), Mixed hard disk(modern hard disk)

Introduction to Hard Drive

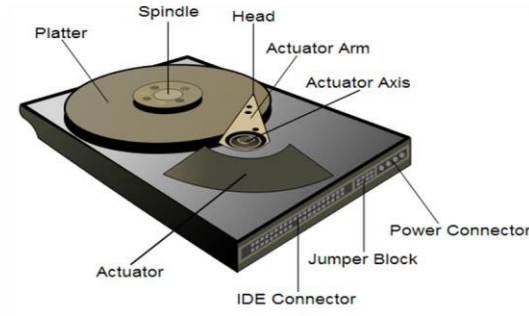
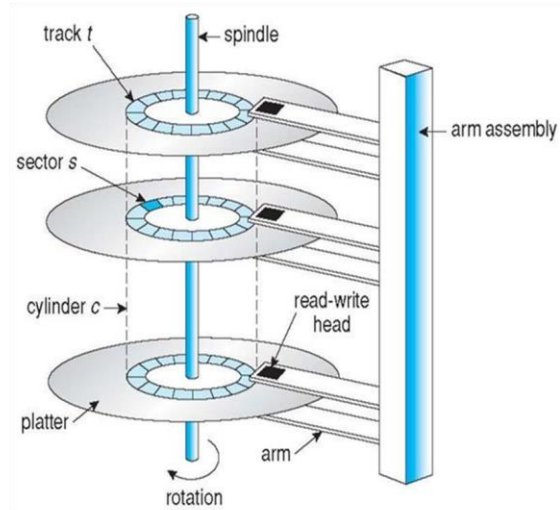

Fig: Hard Drive



Structure of hard disk

Components of an HDD

- **Platters:** Disks coated with a magnetic material where data is stored. Typically, an HDD has multiple platters stacked on a spindle.
- **Spindle:** The axis that holds the platters and spins them at high speeds, typically ranging from 5,400 to 7200 RPM (revolutions per minute).
- **Read/Write Heads:** Tiny magnetic heads located on an actuator arm, responsible for reading data from and writing data to the platters.
- **Actuator Arm:** Moves the read/write heads across the platters to access different data tracks.
- **Actuator:** A motor that controls the movement of the actuator arm.
- **Heads:** The number of heads is relative to the total number of sides of all the platters used to store data. If a hard disk drive has four platters, it can have up to eight heads.
- **Track :** Each surface of platter is divided into number of concentric rings is called track.
- **Cylinder:** The collection of all track that are same distance from the edge of the platter is called cylinder.

Class 10 Computer Hardware , Electronics , repair and maintenance

- **Sector:** Each track is further broken down into smaller units called sectors. As sector is the basic unit of data storage on a hard disk. The data size of a sector is always a power of two and is almost always either 512 MB.

Partitioning, partition size and Drive lettering

Partitioning:

A disk partition or partition is a section of a hard disk separate from other sections. Partitioning divides a hard drive into multiple logical storage units within one drive, but functions as multiple drives. Microsoft operating systems divide hard disks into drives. The first drive partition contains a drive called the primary drive, usually "C:", this is the active partition that boots the operating system." D:" and 'E:" has multiple drives and is used for other storage such as programs, data files, CD-ROMs, and USB drives. Some older versions of Unix OS such as Linux and Mac OS X use multiple partitions from secondary storage to disk. This is called a swap partition or paging.



Purpose of partitioning hard disk:

- Use of New Hard Disk
- Ease of Windows Reinstallation
- Better Organization
- Easier Backup
- Simpler Data Recovery

Why we need partitioning in computer system?

Partitioning a hard disk is essential for several reasons:

- **Organization:** It helps in organizing data by separating the operating system, applications, and personal files into different sections.

Class 10 Computer Hardware , Electronics , repair and maintenance

- **Performance:** Partitions can improve performance by reducing the time needed to access files.
- **Backup and Recovery:** It simplifies the process of backing up and recovering data, allowing users to restore specific partitions without affecting others.
- **Multiple Operating Systems:** Partitions enable the installation of multiple operating systems on the same hard disk.
- **Security and Management:** It enhances security and management by isolating sensitive data and making it easier to manage disk space.

Types of Partitions

- **Primary Partitions:** These are the main partitions on a hard drive where you can install the OS. A hard drive can have up to four primary partitions. One of these partitions can be marked as active, from which the computer boots.
- **Extended Partitions:** If more than four partitions are needed, one of the primary partitions can be designated as an extended partition. This extended partition can contain multiple logical partitions.
- **Logical Partitions:** These reside within an extended partition. They are used to overcome the limitation of having only four primary partitions.

Partition size:

Partition size on a hard disk refers to the specific amount of disk space allocated to a particular partition. A partition is a defined segment of a hard disk's total storage capacity, and partitioning is the process of dividing a hard disk into one or more distinct regions. These partitions can be used to separate different types of data, run multiple operating systems, or manage storage more efficiently. Key concept of partition size are, total size, used and free space , maximum size etc.

Drive Letter:

A drive letter is a single alphabetic character A through Z that is assigned to a physical computer drive or drive partition. For example, floppy disk drive has a drive letter of A: and B: assigned to the drive computers containing hard drive always have that default hard drive assigned to a C: drive letter and the CD-ROM or another disc drive is the last drive letter (e.g. D: drive)

Formatting and types

Formatting:

Disk formatting is the process of preparing a data storage device such as a hard disk drive, solid-state drive, floppy disk, memory card or USB flash drive for initial use.

Format disk is erasing the operating system data from the disk and organizing the available space for further use. Formatting a disk will delete data and provide a new and blank disk. Usually, we can format a disk if we want to use a new system or if we need extra space in our drive.

Class 10 Computer Hardware , Electronics , repair and maintenance

How to perform formatting ?

Formatting a Disk on Windows

1. **Backup Data:**
 - Ensure all important data on the disk is backed up.
2. **Open Disk Management:**
 - Right-click on the Start button and select "Disk Management" or press Win + X and choose "Disk Management".
3. **Select the Disk:**
 - In the Disk Management window, find the disk you want to format.
 - Right-click on the partition you want to format and select "Format".
4. **Configure Formatting Options:**
 - Choose the file system (e.g., NTFS, FAT32, exFAT).
 - Enter a Volume Label (optional).
 - Select the allocation unit size (usually, the default is fine).
 - Choose whether to perform a quick format (recommended) or a full format.
5. **Start Formatting:**
 - Click "OK" to start formatting. Confirm any warning messages that appear.

Advantages of formatting a disk

- Formatting removes all data from the disk, like unused files, and virus or malware which can improve the performance of the storage device.
- Formatting allows you to start fresh, error-free file system, which helps in better organization and file management.
- Fixes file system errors and corruption, ensuring that the storage space is used efficiently.
- Regular formatting can help in maintaining the disk's health by preventing future errors and corruption.
- Formatting allows to partition the disk as needed, optimizing the use of disk space for different types of data.

Formatting types

There are two types of formatting :

a. Low-level formatting:

- Low-level formatting is a process of initializing a disk at the physical level, which includes the creation of tracks, sectors, and other physical parameters that define how data is stored on the disk. This type of formatting is typically performed by the manufacturer before the device is sold and is rarely necessary for end-users.

Advantages of Low-level formatting

- It can sometimes help to fix physical issues with a disk, such as bad sectors or read/write errors.

Disadvantages of Low-level formatting

- It is a complex process that should only be attempted by experienced users or professionals.

b.High-level formatting:

It is the process of creating an empty file system on a hard drive partition or logical volume and installing a boot sector on PC. Often performed quickly, sometimes called quick format. It erases hard drive data, generates boot information , initializes the FAT, and flags logical bad sector if the partition exists.

Advantages of High-level formatting

- It is a simple process that can be performed by most users without any special expertise.

Disadvantages of High-level formatting

- It erases all data from the disk, so it should be done with caution to avoid accidentally deleting important files.

Technotesolution

Class 10 Computer Hardware , Electronics , repair and maintenance

UNIT -4 Troubleshooting techniques

Troubleshooting

Troubleshooting is the method of finding the cause of a problem and correcting it. In other words troubleshooting is the systematic approach to problem solving ,commonly used to find and fix problem in complex mechanical, electronic, computer and software system. The ultimate goal of troubleshooting is to get the equipment back into operation. The first step in troubleshooting method is to gather information about the problem, such as Unwanted behavior or a failure to perform as expected.

Steps of Troubleshooting:

1. Information gathering
2. Analysis and planning
3. Implementation of a solution
4. Assessment of the effectiveness of the solution
5. Documentation.

1.Information gathering

Gathering information is the first step of the troubleshooting techniques. If there is any problem in the system we have to collect necessary information about the problem which helps us to reach at the root cause of problem. It also helps to check that all services are running properly.

2. Analysis and planning :

After identify the exact cause of the problem and creating an action plan for the problem, analyze the data. The main task at this step is to look for pattern. As important part of the analysis phase is prioritization . The includes prioritizing when there is multiple issues. Performance issue are the generally pressing than access issue.

3. Solution implementation:

A problem may have multiple possible solution ,but we recommended making one change at a time. Evaluate the consequences of this change before trying anything else. Doing this will ultimately save your time in the long run.

Class 10 Computer Hardware , Electronics , repair and maintenance

4. Assessment of the effectiveness of the solution

It is vital that you assess the results of your actions and determine whether the "fix" worked, whether it was a temporary work around, or whether it caused additional problems. If possible, have the customer verify the functionality of the solution and system.

5.Documentation

After completing your assessment, you should develop a summarization of the problem, which should include the reported and observed symptoms, the corrective actions taken, and the results of those actions.

- A. Description of the problem.
- B. Steps to resolve the problem.
- C. Components used in the repair.

Troubleshooting boot problems:

Troubleshooting boot problems involves a systematic approach to diagnose and fix issues preventing a computer from starting up correctly. Here's a step-by-step guide:

1. Initial Assessment

Check Power Supply: Ensure the computer is plugged in and the power outlet is working. For laptops, make sure the battery is charged and the power adapter is connected.

Listen for Beeps: Many computers emit beep codes during POST (Power-On Self-Test). These beeps can indicate specific hardware issues.

2. Basic Hardware Checks

Check Connections: Ensure all cables are securely connected, including power cables, data cables (SATA, IDE), and internal connections like RAM and CPU.

Disconnect External Devices: Unplug unnecessary peripherals (USB drives, external hard drives, printers) to rule out external hardware conflicts.

3. BIOS/UEFI Check

- **Access BIOS/UEFI:** Enter the BIOS/UEFI setup (usually by pressing a key like F2, F10, Delete, or Esc during startup).

Class 10 Computer Hardware , Electronics , repair and maintenance

- **Check Boot Order:** Ensure the boot order is correct (e.g., the primary hard drive is set as the first boot device).

4. Scan for viruses and malware

Another possible cause of computer boot issues is a virus or malware infection that affects your system files, your boot sector. These malicious programs can prevent your computer from booting up normally. To scan for viruses and malware, you need to use a reliable antivirus or anti-malware software that can remove viruses from the computer.

5. Boot computer from safe mode:

Although safe mode is simple method for restarting a computer, some function will be disable .

6. Reinstallation and Data Recovery

Repair Installation: Attempt a repair installation of the operating system. This can fix corrupted system files without deleting personal data.

Reinstall OS: If all else fails, reinstall the operating system. Ensure you back up important data before proceeding.

Troubleshooting boot time error messages:

When the system has problem starting it might display error message at setup. These messages might come from the system BIOS or might be generated by windows. This is called boot time error message.

Some boot time error messages are:

- Operating system missing.
- No Boot Device Found" / "Boot Device Not Found
- Disk boot failure.
- CMOS date and time not set.
- CMOS battery failure.

Troubleshooting error messages on OS startup requires first identifying the exact message and its meaning.

Different OS may display error messages in different ways, such as text, codes, symbols, or graphics. some commonly facing boot time error message and solution are :

1. "Disk Boot Failure" Imp

Every time you turn on your computer, as part of the boot process ,the BIOS find a bootable drive, initialize the first sector and continue loading ,however , if the BIOS cannot find the drive to boot, it displays a disk boot failure error screen message and stops boot process. Causes of these error:

- a. **Incorrect BIOS boot order**
- b. **Faulty data cables**
- c. **HDD is damaged**

Fixing this problem with the help of given techniques

- **Check Connections:** Ensure the SATA cable with hard drive is connected properly.
- **Inspect Cables and Ports:**

Class 10 Computer Hardware , Electronics , repair and maintenance

Use different SATA cables or try different SATA ports on the motherboard to rule out faulty cables or ports.

Test Hard Drive: Use diagnostic tools to check the health of the hard drive.

- **Bios setup:** Change the order to position the hard disk as the 1st option.
steps: 1. Goto BIOS setup with the keys like F10, F8, F12 or Del .
2. Goto Boot menu
3. Move the hard disk to the first option by changing the order
4. Save this setting or press F10 key and restart the computer.
- **Replace Drive:** If the hard drive is failing, replace it and reinstall the operating system

2.CMOS Date and Time Not Set"

This error message typically indicates that your computer's CMOS (Complementary Metal-Oxide-Semiconductor) battery is failing or has lost its charge. Here's how you can troubleshoot and resolve this issue: a. **Set the Date and Time in BIOS/UEFI**

- Restart your computer and enter the BIOS/UEFI setup by pressing a key like F2, F10, Delete, or Esc immediately after powering on an enter in BIOS setting .
- Look for a menu or option labeled "Date and Time" or similar. And set correct date and time and press F10 to save. And restart the computer.

b. Replace the CMOS Battery

The most common cause of this error is a dead or weak CMOS battery. The CMOS battery is usually a coinshaped CR2032 battery found on the motherboard. After install new CMOS battery you need to repeat above bios date and time setting process.

c. Consider Hardware Issues

If replacing the CMOS battery and updating the BIOS/UEFI do not resolve the issue, there may be a hardware problem with the motherboard. In this case, consult a professional technician for further diagnosis and repair.

Troubleshooting System Slowdowns:

System slow-down refers to system work slow when we used and open it due to the viruses and other reasons. **Some reasons to system slowdown:**

- Processor overheating
- Bad RAM
- Disk type and interface may be system slow down.
- The programs you have which don't use may be system slowdown.

Class 10 Computer Hardware , Electronics , repair and maintenance

- Your system ROM is too gusty.
- Your PC is infected with virus.
- Your hard drive is full.
- Your PC is too old.
- Your computer is too hot.

Troubleshooting System Slowdowns:

1. Uninstall unused programs

There are many unused program in computer that run background which slowdown the system performance. To remove them, click Start, go to Control Panel, click Programs and Features, scroll through the list, and uninstall the ones you don't use.

2. Delete temporary files

There are a lot of temporary file in the system including browsing history . This may slowdown the computer too. So to remove these press windows+R and search %temp% and delete all temporary files.

3. Install a solid-state drive

It read data much faster and faster booting too, increase system performance

4. Stop unnecessary start ups

Several programs automatically run in the background when you turn on your PC. Disable all these unnecessary programs to increase system performance.

5. Install antivirus programs

Viruses may slowdown the computer performance so to remove viruses and malware use and regular scan antivirus software.

6. Clean PC instantly.

Remove dust from pc , regular maintenance pc and use thermal paste to cool down the system . These helps to increase system performance.

7. Install system update

Regular update system with new features this automatically solve many problem and increase system performance.

8. update system memory:

A lot of files and program take more space in storage which may slowdown the system so use more capacity storage device and memory to increase system performance.

General troubleshooting techniques:

In computer system you may face general types of problem while working on computer which may stop your task. In this time you have to implement some techniques to fix the problem. Here are the some techniques that may help to fix your problem :

a. **Free up RAM by closing other open program:**

When we open many program at the same time our computer utilize more RAM. Which may cause the opened program operating slowly or not start the program. So first, we need to shut all the other opened program.

b. **Restart the software:**

When we facing software issue during the working or starting the software, it may be fixed by restarting the software in many cases.

c. **Shut down and restart the computer:**

This techniques may fixed many general problem while working on the system. If we face general problem during working on computer and we have no idea how to fix that , in this case , shut down and restart the computer may be a best solution to fix the issue.

d. **Use the internet to find help:**

While we experienced problem (software or hardware issue) , we can use internet to find the solution. During find the solution on the internet first you need to explain clearly about the problem including software program, version, issue we ran into and error message too. We also get help with the help of vendor website , they may offer some kind of product assistant to solve the problem . We can use the other website or tutorials to solve the problem .

e. **Undo any recent hardware or software changes:**

When we install new software as well as connection some external hardware(pendrive, printer, scanner) may cause conflict with other program .some time knowingly or unknowingly some setting changes may be happened, this may also produce the problem. So it is good solution to undo all the hardware or software changes to fixed the problem on the case of above mention.

f. **Uninstall the software and reinstall it.**

While working on software sometime it may not work properly or faulty work. This problem may occur due to old version, software updating by company, software removed from main source etc. so in this time totally uninstall and reinstall the software may fixed the issue.

g. **Look for software patches:**

Program developer can also remedy known issues by releasing patches, which are brief software upgrades.

There might be a more recent patch available for the software we are using, even if it's the most recent version.

Class 10 Computer Hardware , Electronics , repair and maintenance

h. Scan for viruses and malware:

Software can freeze, crash or stop functioning altogether due to the viruses, spyware and other types of harmful software(malware). So we need to scan regularly our computer with antivirus or anti-malware software that detect the harmful program or virus and remove from the computer. And fixed the software problems.

Q. How low quality processor lead to the system slowdown? Explain. (SEE 2080)

A processor's quality and specifications play a crucial role in determining the overall performance of a system. Here are some ways in which a low-quality processor can lead to system slowdowns:

1. **Clock Speed:** A low-quality processor may have a slower clock speed, which means it takes longer to process tasks. This can result in delays and slower performance.
2. **Number of Cores:** A low-quality processor may have fewer cores or outdated technology, limiting its ability to efficiently distribute workload. This can lead to slower performance, particularly when running applications that require parallel processing.
3. **Cache Size:** A processor with a smaller cache size may struggle to access data quickly, resulting in slower performance when accessing and processing information.
4. **Instruction Set Architecture (ISA):** The ISA of a processor defines the set of instructions it can execute. Older or low-quality processors may have outdated ISA, leading to inefficiencies in executing new software and instructions. This can cause compatibility issues and slower performance when running newer applications.
5. **Power Efficiency:** Low-quality processors may consume more power or generate more heat, leading to increased power consumption and thermal issues. Operating under these conditions can cause the processor to slow down to prevent overheating or power consumption spikes.

In conclusion, a low-quality processor can lead to system slowdowns due to limitations in clock speed, core count, cache size, ISA, thermal management, and power efficiency. Upgrading to a higher-quality processor with better specifications can improve system performance, reduce bottlenecks, and provide a smoother computing experience.

If your computer reports insufficient memory, what are the causes and solution of this problem.

(SEE 2080)[M-5]

If your computer reports insufficient memory, it means that it is running out of available RAM (Random Access Memory) to handle tasks and applications effectively. This can lead to system slowdowns, freezing, crashing, or error messages indicating low memory. Here are some common causes of insufficient memory and potential solutions:

Causes of Memory Insufficiency:

1. Running Multiple Programs or applications simultaneously can consume a significant amount of RAM.
2. Opening and using large files, such as high-resolution images, videos, or games, can quickly deplete available memory.
3. Some programs and services run in the background and consume memory even when not actively used.
4. Computers with limited RAM capacity may struggle to handle modern software and tasks that require more memory.
5. Certain software applications may have memory leaks, causing them to use more memory.

Solutions to Insufficient Memory Issues:

1. Close any unnecessary programs and browser tabs to free up memory for the applications you are actively using.
2. Rebooting the computer can help clear the memory and close any lingering processes that may be consuming memory unnecessarily.
3. Consider upgrading the computer's RAM to a higher capacity.
4. Disable unnecessary startup programs to reduce the memory usage during boot-up and everyday use.
5. Make sure that the operating system and software applications are up to date, as updates may include memory usage optimizations and bug fixes.

By addressing these causes and implementing the suggested solutions, you can effectively manage and resolve issues related to insufficient memory on your computer.

How to troubleshooting wireless connectivity problem?

When experiencing a wireless connectivity issue, there are several steps you can take to diagnose and potentially resolve the problem. Here is a systematic approach to troubleshooting wireless network issues:

1. Check Basic Connections

Make sure that Wi-Fi is turned on your device. Ensure that Airplane Mode is off, as this will disable all wireless communications.

2. Restart Devices

Restart the computer, smartphone, or tablet experiencing the issue.

Power cycle your router and modem by unplugging them for about 30 seconds and then plugging them back in.

3. Verify Network Settings

Select the Correct Network and ensure that you enter the correct password..

4. Check Signal Strength: Ensure that you are within range of your Wi-Fi router and that there are no physical obstructions or electronic devices causing interference. Move device Closer to the Router to improve signal

5. Run Network Troubleshooter: Most operating systems have built-in troubleshooters. For example, Windows has a "Network Troubleshooter" that can be run from the Control Panel or Network settings.

6. Update Network Drivers: Ensure that your device's wireless network adapter drivers are up to date. Check the manufacturer's website for any firmware updates for your router.

7. Forget and Reconnect: On your device, forget the network and then reconnect by entering the password again.

8. Contact Your ISP: There may be outages or issues on the service provider's end

Troubleshooting specific components:

Computer consist of different components. Whenever any components fail to work, it has impact on the system. Any component failure may have impact on certain functionality or the entire system operation may be affected.

When troubleshooting a specific system or component, keep in mind that the main cause of a problem is unrelated to the area of the PC exhibiting the issue. Furthermore, a failed component is frequently the result of improper configuration or wrong connection. Every component has certain configuration file and script for proper functioning. It must be properly used and configured to avoid failure of specific components.

Class 10 Computer Hardware , Electronics , repair and maintenance

Troubleshooting specific components require that we use exact design and configuration as given by the manufacturer. If any component fails we have to check the design given by manufacturer. We must follow the manufacturer instructions to troubleshoot any components failure.

Troubleshooting specific components:

1. Troubleshooting Dysfunctional USB port

- a. Restart the pc
- b. Uninstall the port driver
- c. Disable USB selective suspension

2. PC does not use a portion of RAM

Your PC may not be using some of your RAM. For example, even though he has 4 GB of RAM, the PC is using only 2 GB of him when I check in Task Manager This is usually a Windows configuration issue.

Note: If only a few MBs (200-400MB) of RAM is not being used, then it is probably being used by the PC hardware and you cannot do anything about it.

1. Open System Configurations.
2. Click on Boot tab and select advanced option.
3. Now check the checkbox next to Maximum memory and enter the maximum amount RAM you have installed (in MBs).
4. To make it take effect, click OK and restart the computer.

There is also a possibility that one of the RAM was improperly installed if this did not resolve the issue. Try reinstalling it.

3. Troubleshoot monitor failure:

A monitor failure refers to the situation where a computer monitor stops functioning properly or stops working altogether.

Here are step-by-step instructions on how to troubleshoot monitor failure:

- a. **Check the power source:** Ensure that the monitor is properly plugged into a working power outlet and that the power cable is securely connected to the monitor.
- b. **Check the connections:** Make sure that the video cable (HDMI, VGA, DVI, etc.) is securely connected to both the monitor and the computer or other source device.
- c. **Test the monitor:** Try connecting the monitor to a different device, such as a laptop or another computer, to see if it works with that device.

Class 10 Computer Hardware , Electronics , repair and maintenance

- d. **Adjust the brightness and contrast settings:** Sometimes, the monitor may in dark mode that means it does not display anything.
- e. **Check for physical damage:** Inspect the monitor for any physical damage, such as cracks in the screen or missing buttons.
- f. **Update or reinstall monitor drivers:** If the monitor is connected to a computer, try updating or reinstalling the monitor drivers.
- g. **Test with a different cable:** If possible, try replacing the video cable with a different one to rule out any issues with the cable itself.
- h. **Perform a factory reset:** Some monitors have a factory reset option in the settings menu. Performing a factory reset can sometimes resolve display issues.
- i. **Contact technical support:** If none of the above steps work, consider contacting the manufacturer's technical support for further assistance or to inquire about repair options.

By following these troubleshooting steps, you should be able to identify the cause of the monitor failure and take appropriate action to resolve it.

4.Blue Screen of Death (BSOD)

Blue Screen of Death is a critical system error screen displayed by the Windows operating system when it encounters a fatal error that it cannot recover from, forcing the system to stop and restart.

Causes of the Blue Screen of Death (BSOD) can vary but often include:

- Incompatible or outdated device drivers
- Problems with hardware components such as faulty RAM, failing hard drives, or overheating
- Conflicts between software applications, corrupted driver, or malware
- Misconfigured BIOS setting

Solutions to the Blue Screen of Death (BSOD) error include:

- **Restart the computer:** Restart can resolve temporary issues causing the BSOD.
- **Update drivers:** Make sure all device drivers are up to date.
- **Check hardware:** Test hardware components such as RAM, hard drives, and graphics cards for any faults or issues.

Class 10 Computer Hardware , Electronics , repair and maintenance

- **Use System Restore:** Roll back to a previous system restore point when the system was functioning correctly.
- **Run Windows Memory Diagnostic:** Check for memory problems that could be causing the BSOD.
- **Reinstall Windows:** If all else fails and the BSOD persists, reinstalling Windows may be necessary to resolve underlying system issues.

It's crucial to note that the Blue Screen of Death often provides an error code or message that can help

identify the specific cause of the issue, which can be used to troubleshoot and resolve the problem effectively.

New Application is not install on PC

There could be several reasons why a new application is not installing on a PC. Here are some common causes and potential solutions:

Causes:

1. Insufficient disk space
2. Compatibility issues:
3. Corrupted installation file:
4. User permission issues:
5. Running background processes:

Solutions:

1. **Free up disk space:** Delete unnecessary files or programs to create more space on the hard drive for the new application.
2. **Check compatibility:** Verify that the application is compatible with the PC's operating system and hardware specifications.
3. **Download a fresh copy:** Download the latest version from the the official website.
4. **Run as administrator:** Right-click on the installation file and select "Run as administrator" to ensure that you have the necessary permissions to install the software.
5. **Disable background processes:** Temporarily disable antivirus software or other background processes that may interfere with the installation process.
6. **Use compatibility mode:** Right-click on the installation file, go to Properties, and set compatibility mode to an earlier version of Windows if the application is not compatible with the current version.

UNIT -5 REPAIR AND MAINTENANCE

Preventive maintenance of the system:

Preventive maintenance is important to keep your computer running smoothly and to prevent potential issues from arising.

A **preventive maintenance system** refers to a proactive approach to maintaining equipment, systems, or infrastructure. It involves performing regular inspections, servicing, and repairs to prevent potential problems before they occur. The goal of preventive maintenance is to extend the lifespan of assets, reduce the possibility of unexpected failures, and minimize downtime.

Preventive maintenance for software:

1. **Regular Updates:** Apply patches and updates to software, OS, and dependencies.
2. **Backups:** backup your software this may help to recover when unexpectedly remove from your system.
3. **Performance Monitoring:** Optimize performance and resource usage.
4. **Bug Fixes:** Address errors and bugs and debugs(correct) them.
5. **Documentation:** Keep user and technical documentation up to date.
6. **License Management:** Ensure software licenses are current.
7. **Compatibility Checks:** Test for compatibility with new hardware or software.
8. **Security Audits:** Scan for vulnerabilities and viruses they may corrupt the software. . These actions help prevent software failures and extend its lifecycle.

Preventive maintenance for internal parts of a computer

Ensures optimal performance and extends the lifespan of hardware components. Key tasks include:

1. **Cleaning:** Regularly clean dust from internal components like the CPU, GPU, fans, and power supply to prevent overheating.
2. **Checking Connections:** Ensure that cables, connectors, and internal parts are properly seated and securely connected.
3. **Cooling System Maintenance:** Clean or replace fans, and check thermal paste on the CPU to prevent overheating.
4. **Hard Drive Maintenance:** Run disk checks and defragmentation (for HDDs) to ensure data integrity and prevent data loss.
5. **Power Supply Checks:** Inspect the power supply for wear and tear, and ensure it's providing consistent voltage.
6. **Memory (RAM) Checks:** Run memory tests to identify faulty RAM modules and replace if necessary.
7. **Component Upgrades:** Periodically review internal hardware to upgrade outdated components for better performance.
8. **Battery Checks (for laptops):** Calibrate and replace batteries when their capacity depletes significantly. These steps help in maintaining the computer's performance and preventing hardware failures.

Class 10 Computer Hardware , Electronics , repair and maintenance

Preventive maintenance from dust:

Preventive maintenance to protect a computer from dust involves regular cleaning and protective measures to avoid dust build up, which can cause overheating and component damage. Here's what you can do:

- Regularly clean external and internal components.
- Use compressed air to remove dust from internal parts like the CPU, GPU, and fans.
- Clean fans and vents to maintain proper airflow.
- Clean keyboard and mouse with compressed air or a soft brush.
- Install dust filters on air intake vents and clean or replace them regularly.
- Place the computer in a well-ventilated area, elevated from the ground.
- Keep the computer away from dust sources like carpets or open windows.
- Use dust covers for the computer and peripherals when not in use.

These actions help keep your computer dust-free and improve its performance and longevity.

Power source in computer:

The **power source** for a computer is typically an external electrical supply connected to the computer through a power supply unit (PSU). The PSU converts alternating current (AC) from the mains into low-voltage direct current (DC) that the internal components of the computer use. In laptops, the battery serves as a power source when not connected to a direct power outlet. Stable and reliable power is essential for a computer's performance and longevity.

Power protection

Power protection in computers is crucial to safeguard the system from electrical disturbances that can damage hardware, corrupt data, or cause sudden shutdowns. Electrical problems such as power surges, outages, spikes, and fluctuations can affect a computer's sensitive components, making power protection devices essential for ensuring the system's longevity and reliability.

Power protection devices:

1. **Surge Protectors:** These devices shield the computer from power surges, which occur when there is a sudden spike in voltage. A surge can happen during lightning strikes or issues in the power grid. Surge protectors divert the extra voltage away from the computer, preventing damage to internal components like the motherboard, CPU, and hard drive.

How It Works: It contains components like metal oxide varistors (MOVs) that absorb and redirect excess voltage away from the connected devices.

Class 10 Computer Hardware , Electronics , repair and maintenance

- Uninterruptible Power Supply (UPS):** A UPS is a backup power device that provides temporary power to a computer in the event of a power outage. It allows users to save their work and shut down the system safely, preventing data loss. Additionally, a UPS can protect against voltage fluctuations and momentary dips in power, ensuring a stable power supply.
How It Works: A UPS contains a battery that kicks in when the main power supply fails. It also often includes surge protection and voltage regulation functions to protect against power fluctuations and surges.
- Voltage Regulators:** Voltage fluctuations, such as under-voltage (brownouts) and over-voltage, can harm the computer's components or cause instability. A voltage regulator ensures the computer receives consistent voltage, correcting the power supply when it deviates from safe levels.
How It Works: It monitors the incoming voltage and adjusts it to the required level, either by boosting low voltage or reducing high voltage.
- Power Conditioners:** These devices clean the power by filtering out noise, spikes, and electrical interference that can affect the computer's performance. Power conditioners ensure that the power entering the computer is stable and free of disturbances.
How It Works: It uses filters and other components to remove unwanted electrical noise and smooth out the power signal. This ensures that the power delivered to the computer is clean and stable.

By using these power protection solutions, computers are safeguarded against electrical risks, ensuring smoother operation, protecting valuable data, and prolonging the life of hardware components.

Steps to Defragment Hard Disk in Windows:

1. Type "Defragment" or "Defragment and Optimize Drives" in the search bar.
2. Select "Defragment and Optimize Drives" from the search results.
3. Select the Drive to Defragment:
4. Click on the "Optimize" button to start the defragmentation process.

This can take some time depending on the size and fragmentation level of the disk.

Schedule Regular Defragmentation (Optional):

You can set a regular schedule for disk optimization by clicking on the "Change settings" button.

Steps to Perform Disk Cleanup in Windows:

1. Click on "Disk Cleanup" from the search results.
2. Select Drive for Cleanup:
3. Choose the C: drive (or any other drive you want to clean) and click OK.
4. Select the types of files you want to delete by checking the boxes (e.g., Temporary Internet Files, System Error Memory Dump Files, etc.).
5. Delete System Files (Optional):

Class 10 Computer Hardware , Electronics , repair and maintenance

6. For more options, click on the "Clean up system files" button.
7. Select the drive again and wait for the additional system files list to appear (this may include Windows Update Cleanup, old Windows installations, etc.).
8. Confirm Deletion:
9. After selecting the files, click OK, and a confirmation window will pop up.
10. Click "Delete Files" to proceed with the cleanup. Wait for the Cleanup to Finish:

Video card /Graphic card:

A **video card**, also known as a **graphics card** or **GPU (Graphics Processing Unit)**, is a critical component in a computer responsible for rendering images, video, and animations. Here's an overview:

- **Primary Function:** The video card processes and outputs visual data to the computer's display. It handles complex calculations related to image rendering and can significantly impact the quality and performance of graphics in applications and games.
- **Components:**
- **GPU:** The core processor that performs the calculations needed for rendering images and video. It executes thousands of parallel operations to handle graphics tasks efficiently.
- **Video Memory (VRAM):** Dedicated memory on the graphics card used to store textures, frame buffers, and other data needed for rendering. VRAM allows the GPU to access data quickly, which is crucial for smooth graphics performance.
- **Cooling System:** Most video cards have fans or heat sinks to dissipate heat generated by the GPU during operation, ensuring stable performance and preventing overheating.

Example of graphics card: NVIDIA RTX 4090, AMD Radeon RX 7900 XTX, NVIDIA GeForce GTX 1660 Super, AMD Radeon RX 6600 XT, NVIDIA Quadro RTX 8000.

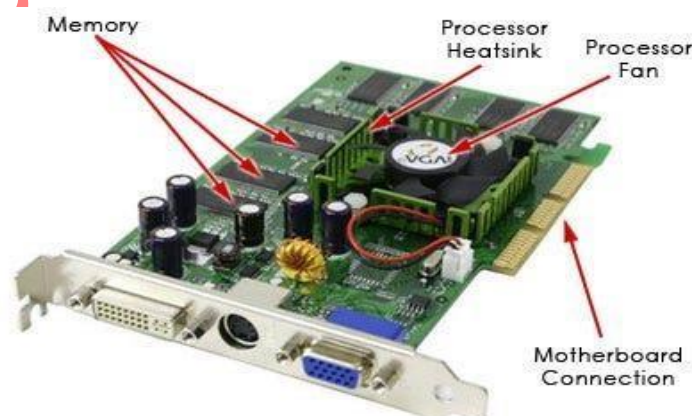

Fig: Graphic card

Class 10 Computer Hardware , Electronics , repair and maintenance

Causes of graphic card failure:

- **Power Supply Issues:** Inadequate or unstable power supply can cause power-related problems or failure of the graphics card.
- **Driver Problems:** Outdated, corrupted, or incompatible drivers can lead to graphical glitches, crashes, or failure.
- **Physical Damage:** Damage from improper handling, electrical shorts, or manufacturing defects can cause the card to malfunction.
- **Overheating:** Insufficient cooling or dust buildup can cause the GPU to overheat, leading to damage or failure.
- **Dust and Debris:** Accumulation of dust and debris in the GPU fans and heatsinks can impair cooling and lead to overheating.
- **Incompatible Hardware:** Mismatched components or incompatible system configurations can cause issues with the graphics card.
- **VRAM Issues:** Faulty or insufficient VRAM can result in graphical artifacts, crashes, or poor performance.

Effects of graphic card failure in computer system:

- The screen may show artifacts, glitches, or be completely blank.
- Graphics-intensive applications and games may run slowly.
- The computer may crash or freeze, particularly when performing tasks that depends heavily on the GPU.
- Visual corruption in images, videos, or user interfaces can occur.
- Frequent error messages related to graphics drivers or hardware may appear.
- The screen resolution may drop, affecting the clarity and quality of visuals.
- General instability and unreliability of the system can result from a failing video card.
- Applications or games that depends on the GPU may not run or may not function correctly.

Solution for graphic card issue:

- **Check Connections:** Ensure that the video card is properly seated in the PCIe slot and that all power connectors are securely attached.
- **Clean the GPU:** Remove dust and debris from the GPU fans and heatsinks to prevent overheating.
- **Update Drivers:** Install the latest graphics drivers from the manufacturer's website to fix compatibility issues and bugs.
- **Test with Another System:** Test the graphics card in another computer to determine if the issue is with the card or other components.
- **Check Power Supply:** Ensure that the power supply is adequate and providing stable power to the GPU.
- **Run Diagnostic Tools:** Use diagnostic software to check the health of the GPU and identify potential hardware problems.
- **Replace Thermal Paste:** Reapply thermal paste if the GPU is overheating due to dried-out or degraded paste.
- **Reset BIOS/UEFI Settings:** Reset or update BIOS/UEFI settings to ensure proper configuration of hardware components.
- **Perform a Clean Install:** Uninstall existing graphics drivers and perform a clean installation to resolve driver conflicts.
- **Consider RMA or Replacement:** If the card is still under warranty, contact the manufacturer for a replacement or repair.

Causes of image quality problem in monitor:

An image quality problem in monitor can be caused by many reasons such as poor resolution setting, mismatched cable connection or dirty screen.

- **Resolution Mismatch:** Using a resolution setting that does not match the monitor's native resolution can cause blurriness or distortion.
- **Poor Connection:** Loose, damaged, or improperly connected cables can lead to poor image quality, such as flickering or artifacts.
- **Driver Issues:** Outdated or corrupted graphics drivers can affect display performance and quality.
-

Class 10 Computer Hardware , Electronics , repair and maintenance

- **Monitor Settings:** Incorrect brightness, contrast, or color settings can impact the overall image quality.
- **Hardware Issues:** Problems with the monitor itself, such as dead pixels, backlight bleeding, or aging components, can lead bad image quality.
- **Graphics Card Problems:** Issues with the graphics card, such as overheating or malfunctioning, can affect how images are rendered on the monitor.

How to fix screen resolution/image quality issue in monitor:

To fix image quality or resolution issues on a monitor, you can follow these steps:

Check Resolution Settings: Ensure that the monitor's resolution setting matches its native resolution.

You can adjust this in the display settings of your operating system.

Update Graphics Drivers: Install the latest drivers for your graphics card from the manufacturer's website to fix compatibility issues and improve performance.

Adjust Monitor Settings: Use the monitor's on-screen display (OSD) menu to adjust brightness, contrast, colour settings, and sharpness to improve image quality.

Verify Cable Connections: Ensure that all video cables (HDMI, DisplayPort, DVI, VGA) are securely connected and not damaged. Try using different cables if necessary.

Check Refresh Rate: Set the monitor's refresh rate to the recommended value in the display settings of your operating system.

Reset Monitor Settings: If all else fails, reset the monitor to its factory default settings using the OSD menu. **Test with Another Device:** Connect the monitor to a different computer or device to determine if the issue is with the monitor or the original system.

By systematically addressing these areas, you can often resolve image quality or resolution problems and restore proper display performance.

Input/Output connection issue causes:

The functioning of the computer system is based on the combined use of input and output devices. An input device allows us to tell the computer to perform an action and the devices returns an action via an output devices.

Due to some factor that cause the input out issue . Such as :

Loose or unsecured cables.	Damaged cables.
Faulty or damaged ports.	Outdated or corrupted drivers.
Incompatible hardware.	Insufficient/unstable power supply.
Software conflicts or OS issues.	Outdated/corrupted firmware.
Physical damage to connectors or ports.	Incorrect system or BIOS/UEFI settings.

Solution for Input/Output connection issues solution :

Input and output device connection issues can be caused by a variety of factors, here are some steps you can take to try and fix the problem:

- Check the connection of the device to the computer, make sure that the cables are securely plugged in and that the connectors are not damaged.
- Check the power supply of the device, make sure that it is connected to a power source and that it is turned on.
- Check the device's settings, make sure that it is configured correctly and that it is set to the correct input or output mode.
- Check for any software updates for the device and the computer.
- Try different USB ports, sometimes the USB ports can malfunction.
- Try a different cable, sometimes the cable can be faulty.
- Try disabling and re-enabling the device in the device manager.

Processor

The processor, or central processing unit (CPU), is the brain of a computer, responsible for executing instructions and performing calculations that drive software applications and system operations. Here's a brief overview: **Function:** The CPU processes data and instructions from software and hardware. It performs tasks such as arithmetic calculations, data manipulation, and control operations to run programs and manage system functions. The main function of processor are fetch(fetching instruction from system RAM) , decode(instruction are converted into understanding form) and execute(operation are performed).

Class 10 Computer Hardware , Electronics , repair and maintenance

Types of processor:

1. Microcontroller: A compact integrated circuit designed to govern specific tasks within embedded systems. It typically includes a CPU, memory (RAM and ROM), and I/O ports on a single chip. Microcontrollers are used in everyday devices like appliances, automotive systems, and electronics.

2. Embedded Processor: A specialized CPU used within embedded systems, tailored for specific applications. It focuses on optimizing performance for dedicated tasks, often with lower power consumption and cost. Embedded processors are found in devices like routers, industrial machines, and consumer electronics.

3. Digital Signal Processor (DSP): A specialized processor optimized for handling digital signal processing tasks, such as audio, video, and image processing. DSPs are designed for high-speed mathematical computations and are used in applications like audio effects, telecommunications, and radar systems.

4. Media Processor: A type of processor designed specifically for handling media-related tasks, including video decoding, encoding, and playback. Media processors are used in devices like smartphones, digital cameras, and media streaming devices to handle complex media operations efficiently.

5. Microprocessor: The central processing unit (CPU) of a computer system, capable of executing a wide range of general-purpose tasks. Microprocessors are the main component of personal computers, laptops, and servers, and they handle various computing operations and system management functions

Voltage level:

Voltage level refers to the amount of electrical potential difference between two points in an electrical circuit. It is measured in volts (V) and indicates the "pressure" that drives electric current through a conductor. Voltage levels can vary depending on the system or device, ranging from low voltage used in small electronics to high voltage in power transmission systems. modern CPU

Operates on the range of 1.0 to 1.5 volts while mobile CPU operates around 0.8v to 1.3 volt.

Types of Voltage Levels:

- 1. Low Voltage:** Typically refers to voltages below 50V. Low voltage is used in devices like smartphones, computers, and household electronics.
- 2. Medium Voltage:** Ranges from 1kV (1,000V) to 35kV. This is commonly used in distribution systems to transfer electricity from substations to consumers.

Class 10 Computer Hardware , Electronics , repair and maintenance

3. **High Voltage:** Voltages above 35kV are considered high. High voltage is used in transmission lines to carry electricity over long distances with minimal loss.
4. **Extra-High Voltage (EHV):** This involves voltages above 230kV, typically used in long-distance, high- capacity power transmission.

Importance of Voltage Levels:

- **Safety:** Different voltage levels come with different risks. Low voltages are safer to handle, while high voltages can be dangerous and require specialized equipment and protection.
- **Efficiency:** High voltage transmission is more efficient for long distances, as it reduces energy loss due to resistance in conductors.
- **Device Compatibility:** Electronic devices are designed to operate at specific voltage levels, and exceeding those levels can damage the device or reduce its lifespan.

Understanding voltage levels is crucial for ensuring the safe and efficient design and operation of electrical systems.

Introduction to Processor cooling:

Processor cooling is the process of removing heat from the processor (also known as the central processing unit or CPU) in a computer. The processor is one of the most heat-sensitive components in a computer, and if it becomes too hot, it can cause the computer to malfunction or even become damaged.

Method/techniques for processor cooling:

If the processor is cooling as needed , it helps to perform operation smoothly to the processor . Here are some techniques how we maintain the processor cool:

1. Heat sink:

A block of metal (usually aluminium or copper), metal bars of metal fins that attach to be processor or other motherboard components. Heat from the processor is transferred to the heat sink and then blown away by the air flow throughout the computer case.

2. Fan:

Fans can be attached to the processor , to the side of the processor and to the case. It regularly provide air to the processor during system is on state.

3. Thermal paste:

Thermal paste compound or grease is applied to the top of the processor before a heat sink is attached. A thermal compound applied between the CPU and heatsink to fill microscopic gaps and improve thermal conductivity.

4. Liquid cooling:

Liquid is circulated through the system via a heat sink mounted on the CPU. Heat from the processor is transferred to the cooler liquid.

Class 10 Computer Hardware , Electronics , repair and maintenance

5. Heat pipe:

A metal tube used to transfer heat away from an electronic component. Heat pipes use a sealed, evacuated tube with a small amount of liquid. As heat is applied, the liquid evaporates, moves to the cooler end of the pipe, and condenses back into liquid. This cycle efficiently transfers heat from the CPU to a heatsink or radiator. Especially used in laptop.

6. Passive cooling:

Passive cooling involves no fans, so a heat sink that doesn't have a fan attached is known as a passive heat sink.

7. Processor socket and slot:

The processor socket (also called CPU socket) is the connector on the motherboard that houses a CPU and forms the electrical interface and contact with the CPU. Processor sockets use a pin-grid array (PGA) where pins on the underside of the processor connect to holes in the processor socket.

8. Peltier (Thermoelectric) Cooling

Utilizes a thermoelectric module (Peltier device) that creates a temperature difference when electrical current flows through it. One side of the module becomes hot while the other side becomes cold.

System cooling :

It refers to the methods and technologies used to dissipate heat generated by various components in a computer, such as the CPU, GPU, and power supply. Effective cooling ensures that the system operates within safe temperature limits, preventing overheating and maintaining optimal performance.

Why System Cooling is Needed:

- Prevents overheating and hardware damage
- Maintains optimal performance
- Ensures system stability
- Increases component lifespan
- Avoids automatic shutdowns due to high temperatures
- Reduces energy consumption
- Prevents performance throttling during heavy workloads

Ventilation:

Ventilation refers to the process of introducing fresh air into an enclosed space and removing stale or contaminated air. In the context of computers, ventilation refers to the flow of cool air into the computer case and the movement of hot air out of the case. Adequate ventilation is necessary to ensure that the internal components of the computer are kept at a safe temperature and to prevent overheating.

Why ventilation is needed?

- Prevents overheating of internal components. ➤ Enhances system performance and longevity.
- Reduces the risk of hardware damage due to high temperatures.
- Promotes airflow, removing heat generated by the system.
- Reduces fan noise by allowing more efficient cooling.
- Improves stability and reliability during high-intensity tasks

Computer virus background:

A computer virus is a type of malicious software designed to replicate itself and spread from one computer to another, often without the user's knowledge. The concept of computer viruses dates back to the early days of computing in the 1970s and 1980s. The first computer virus in the world is generally considered to be the Creeper virus, which was created in 1971. It was an experimental self-replicating program written by Bob Thomas, an engineer at BBN Technologies. When a computer was infected by Creeper, it would display the message: "I'm the creeper, catch me if you can!" It did not cause harm to files or data, but it is widely considered the first example of a virus-like program.

Virus detection:

Virus detection involves identifying and removing malicious software (viruses) from computer systems. This is an information security process aimed at checking for and identifying dangerous viruses and program . This is the most important features of antivirus software. Modern antivirus software uses several techniques to detect viruses, each with its own strengths:

1. Signature-based detection:

The antivirus compares files on the computer to a database of known virus signatures (unique patterns).

This is the most common method but only works for known viruses.

2. Heuristic analysis:

This method looks for suspicious behavior or code that resembles known viruses, allowing it to detect new, previously unknown viruses or variants. It helps find zero-day threats.

3. Real-time scanning:

This continuously monitors files and network activity to detect and block viruses as they enter the system.

It's essential for preventing infections from spreading.

4. Machine learning:

Some modern antivirus software uses AI and machine learning to detect patterns and predict potentially harmful programs, even if they don't match existing virus signatures.

5. Behavioral detection: Rather than analyzing code, this method monitors the behavior of programs in real-time. If a program exhibits virus-like behavior (e.g., trying to modify system files or spreading to other programs), it is considered as virus .

Types of computer viruses

1. File Infector Virus

A file infector virus attaches itself to executable files such as `.exe` or `.com`. When the infected program is opened, the virus becomes active and spreads to other executable files in the system.

Example: CIH (Chernobyl) virus that infected Windows executable files.

2. Boot Sector Virus

This virus infects the Master Boot Record (MBR) or boot sector of a storage device. It activates when the computer is turned on or restarted.

Example: Michelangelo virus, which infects the boot sector of hard disks and floppy disks.

3. Macro Virus

Macro viruses target applications that use macros, especially Microsoft Word and Excel files. They spread when infected documents are opened.

Example: Melissa virus, which spreads through infected Word documents sent via email.

4. Polymorphic Virus

A polymorphic virus changes its code or appearance each time it spreads, making it difficult for antivirus software to detect.

Example: Storm Worm, which frequently changes its signature to avoid detection.

5. Resident Virus

This virus installs itself in the computer's memory and stays active even after the original infected program is closed. It infects files as they are opened or executed.

Example: CMJ virus , which remains resident in system memory.

6. Direct Action Virus

A direct action virus becomes active only when the infected file is executed. It does not remain in memory after execution.

Example: Vienna virus , which infects executable files when run.

7. Multipartite Virus

This virus uses more than one method to spread, such as infecting both boot sectors and files at the same time.

Example: Ghostball virus , which infects boot sectors and executable files.

8. Trojan Horse (Trojan)

A Trojan appears to be a legitimate or useful program, but once executed, it performs malicious activities such as stealing data or creating backdoors.

Example: Zeus Trojan , used to steal banking and login information.

9. Worms

Worms are self-replicating malicious programs that spread automatically across networks without attaching to a host file. They can consume system and network resources.

Example: ILOVEYOU worm , which spread rapidly through email and networks.

10. Email Virus

Email viruses spread through infected email attachments or malicious links. When the attachment is opened, the virus activates and may automatically send itself to other contacts.

Example: Nimda virus , which spread through email attachments and network shares.

Symptoms of computer when affected by virus:

- 1.Slow system performance or frequent crashes
- 2.Unexpected pop-up ads or error messages
- 3.Programs start or close on their own
- 4.Files or data become corrupted or disappear
- 5.Increased network activity without explanation
- 6.Unusual messages or files sent to contacts
- 7.Inability to access certain files or programs
- 8.Web browser redirects to unknown websites
- 9.Disabled antivirus or security software
- 10.High CPU or disk usage with no apparent cause
- 11.Appearance of unfamiliar icons or programs
- 12.Computer freezes or becomes unresponsive

Ways to virus transfer:

Email attachments: Viruses spread through infected attachments or links in emails.

Malicious downloads: Downloading infected software or files from untrustworthy sources.

Infected websites: Visiting compromised websites that install viruses automatically.

Removable media: USB drives, CDs, or external hard drives carrying infected files.

Infected ads (malvertising): Clicking on malicious advertisements online.

Network connections: Spreading through local networks by exploiting unprotected devices.

Phishing attacks: Misleading emails or messages designed to spread malware.

Pirated software: Without updates or patches, pirated software exposes users to security risks and makes virus infections more likely.

Antivirus software

It is a program designed to detect, prevent, and remove malicious software, such as viruses, worms, Trojans, and other forms of malware. It plays a crucial role in safeguarding computers and networks from cyber threats by scanning, identifying, and neutralizing malicious code before it can cause harm.

Using antivirus software is essential for maintaining the security and integrity of computer systems, preventing data loss, and protecting personal and sensitive information from cybercriminals. Regular updates and scans ensure that antivirus programs can handle new and evolving threats.

Protection method from computer virus:

A computer that is not secured is similar to an open door for computer viruses. Antivirus programs have come a long way in identifying and preventing the spread of computer viruses. However, if your device is infected, we recommend installing an antivirus solution to remove it.

Take these steps to protect your PC with the best computer virus protection:

- 1. Install reliable antivirus software:** Use reputable antivirus programs and keep them updated to detect and remove viruses.
- 2. Keep software updated:** Regularly update your operating system, applications, and security software to patch vulnerabilities.
- 3. Enable firewalls:** Use a firewall to block unauthorized access and potential threats from external sources.
- 4. Avoid suspicious emails and links:** Do not open attachments or click links from unknown or untrusted sources.
- 5. Download from trusted sources:** Obtain software and files from reputable websites and avoid pirated or unverified sources.
- 6. Use strong, unique passwords:** Employ complex passwords and change them regularly to protect against unauthorized access.
- 7. Be cautious with removable media:** Scan USB drives and other removable media for viruses before opening files.
- 8. Practice safe browsing:** Avoid visiting dubious websites and use browser security extensions to enhance protection.

UNIT- 6 BACKUP AND RECOVERY

6.1. Introduction to Backup and Recovery

BACKUP:

Computer backup is a process that copies all your files, data and information the effectively create two various one on your original and one backup. It is designed to protect all of your important files and pictures. Even the ones you save to an external hard drive. A backup is a copy of important data that is made on a regular basis. The purpose of a backup is to ensure that the data can be restored in case of data loss or system failure. Backups can be used to restore a single file, an entire system, or entire network.

RECOVERY:

In computers, recovery refers to the process of restoring a system, application, or data to a functional or original state after experiencing a failure, error, or loss. Recovery ensures continuity and minimizes the impact of problems like hardware malfunctions, software errors, or accidental deletions.

Types of Recovery:

- 1. Data Recovery:** Data recovery involves retrieving lost, deleted, or corrupted files from storage devices like hard drives, SSDs, USB drives, or memory cards. Common causes for data loss include accidental deletion, formatting, malware attacks, or hardware failures.. Preventive measures such as regular backups and using reliable storage devices can significantly reduce the need for data recovery.
- 2. System Recovery:** System recovery focuses on restoring an operating system (OS) to a functional state after crashes, malware attacks, or update failures. This is done through methods like booting into recovery mode, or reinstalling the OS. Many systems come with built-in recovery tools, such as Windows Recovery Environment or macOS Recovery.
- 3. Database Recovery :** Database recovery restores a database to a consistent and usable state after a failure, such as power outages, software bugs, or disk crashes. Recovery relies on techniques like restoring backups, replaying transaction logs, or using checkpoints.

Class 10 Computer Hardware , Electronics , repair and maintenance

- 4. Disaster Recovery:** Disaster recovery refers to strategies for maintaining or restoring IT infrastructure and operations after catastrophic events such as natural disasters, cyberattacks, or system failures. This involves having backups, redundant systems, and failover mechanisms, often supported by cloud-based recovery solutions
- 5. Password Recovery:** Password recovery is the process of resetting or retrieving forgotten passwords for accounts or encrypted files. Tools like password recovery utilities, security questions, or two-factor authentication help users regain access. Many systems offer "Forgot Password" options to reset credentials securely.
- 6. Cloud Recovery:** Cloud recovery is the process of restoring data, applications, or systems stored in the cloud to ensure business continuity after a failure, cyberattack, or disaster. It leverages cloud-based backup and disaster recovery solutions to quickly recover lost or corrupted information without the need for physical infrastructure.

Backup Methods:

A backup method refers to the specific approach or strategy used to create and store copies of data for protection against loss, corruption, or disasters. Each method balances storage space, recovery speed, and data integrity based on specific needs. Various backup methods are: full backup, incremental backup, differential backup, mirror backup, cloud backup, local backup etc.

1. Full backup:

A full backup involves creating a complete copy of all data, regardless of changes since the last backup. This method is comprehensive and provides a straightforward recovery process, as all data is stored in a single location. However, it requires significant time and storage space, making it less suitable for frequent backup. Example: A company performs a full backup of its database every Sunday night, storing the complete data set on an external hard drive to ensure data integrity for the week ahead.

Advantages:

- Complete data protection
- Faster recovery

Class 10 Computer Hardware , Electronics , repair and maintenance

Disadvantages:

- a. Full backups require a large amount of storage
- b. The process of creating a full backup can take a long time

2. Incremental Backup:

An incremental backup only copies the data that has changed since the last backup (whether full or incremental). It is efficient in terms of storage and time but can complicate recovery, as multiple incremental backups must be restored in sequence. Example: After performing a full backup on Sunday, a business runs daily incremental backups, saving only the files updated on Monday, Tuesday, and so on. This reduces backup time and storage requirements.

Advantages:

- a. Faster Backup Process
- b. Less Storage Space

Disadvantages:

- a. Slower Recovery Time
- b. Risk of Data Loss

3. Differential Backup

A differential backup saves all changes made since the last full backup. Unlike incremental backups, differential backups grow larger over time as they accumulate all changes since the last full backup. While this simplifies recovery, as only the full and most recent differential backups are needed, it requires more storage than incremental backup. Example: After a full backup on Sunday, a differential backup on Wednesday includes changes from Monday, Tuesday, and Wednesday. If recovery is needed, only the Sunday full backup and the Wednesday differential backup are required.

Advantages of Differential Backup:

- a. Faster recovery (only need the last full and differential backups).
- b. Less storage than full backup (stores only changes since the last full backup).

Disadvantages of Differential Backup:

- a. Larger size over time (grows as more changes are included).
- b. Longer backup time than incremental (includes all changes since the last full backup).

4. Mirror Backup

A mirror backup creates an exact replica of the source data, including any deletions or changes. It is useful for maintaining an up-to-date copy but carries the risk of accidental deletions being mirrored to the backup.

Example: A graphic designer uses a mirror backup to keep a real-time copy of their project files on a secondary external drive. If a file is modified or deleted, the change is immediately reflected in the backup.

5. Cloud Backup

A cloud backup involves storing data on remote servers managed by third-party providers. This method offers scalability, accessibility from any location, and protection against local disasters. However, it depends on a stable internet connection and often incurs recurring costs. Example: A small business uses Google Drive to back up its financial records daily, ensuring the data is safe and accessible even if the local office systems fail.

6. Local Backup

A local backup involves saving data to physical storage devices like external hard drives, USB drives etc. It is faster for both backups and recovery compared to cloud backups but is susceptible to risks like hardware failures, theft, or physical damage. Example: A photographer backs up their portfolio to an external SSD after every photoshoot, ensuring quick access to their files in case of a laptop failure

Different between incremental backup and differential backup

Incremental Backup	Differential Backup
Backs up only the data that has changed since the last backup (full or incremental).	Backs up all data that has changed since the last full backup.
Requires less storage space for each backup compared to differential backups.	Requires more storage space as changes accumulate since the full backup.
Backup process is faster because it only captures the most recent changes.	Backup process becomes slower over time as it includes all changes since the last full backup.
Recovery is slower because multiple incremental backups must be restored in sequence.	Recovery is faster since only the last full backup and the latest differential backup are needed.
Ideal for frequent backups with minimal storage requirements.	Better for situations where quicker recovery is prioritized over storage efficiency.

Backup devices and media

Backup devices and media are the hardware and storage formats used to save copies of data for protection against loss. They vary in capacity, speed, portability, and durability, allowing users to choose based on their backup needs.

There are various backup devices and media that can be used to store backups, including:

1. **External hard drives:** These are small, portable devices that can store a large amount of data and can be easily connected to a computer via USB or other types of connections.
2. **Cloud storage services:** These are online storage services that can be used to store backups and other types of data. Examples include Amazon S3, Google Drive, and Microsoft Azure.
3. **Tape drives:** These are devices that can store data on magnetic tape and are commonly used for long-term storage and disaster recovery backups.
4. **Optical media:** These are devices that store data on CDs, DVDs, or Blu-ray discs and are commonly used for archival backups or for backups that need to be stored off-site.
5. **USB Flash Drives :** USB flash drives are small and easy to carry, making them perfect for storing a small amount of data, like documents or photos.

6. Internal Backup Drives

Internal backup drives are hard drives placed inside your computer to store extra copies of your files. These drives are fast and always connected to your computer.

7. Memory Cards (SD Cards)

Memory cards are tiny, portable storage devices often used in cameras and phones. They are good for saving smaller files, like photos, videos, and music.

8. RAID Systems

RAID (Redundant Array of Independent Disks) is a setup where multiple hard drives work together to store data safely. If one drive fails, the others keep the data safe.

Backup scheduling

It is the process of automating the timing of backups to ensure that your data is regularly and reliably copied without needing manual intervention. This is especially important for both personal and business environments, where data loss can be catastrophic. Backup scheduling ensures that your files are backed up consistently and at optimal times, such as overnight or during periods of low activity, without interrupting your daily tasks.

Class 10 Computer Hardware , Electronics , repair and maintenance

Why Backup Scheduling is Important:

1. **Automates the Process:** You don't need to remember to run backups manually. Scheduling automates the process, making it a regular part of your routine.
2. **Prevents Data Loss:** Regular backups minimize the risk of losing important files, whether due to accidental deletion, hardware failure, malware, or other disasters.
3. **Optimizes System Performance:** You can schedule backups to run during periods of low computer or network usage (like at night), so they don't interfere with work hours.

Media Rotation:

Media rotation is the process of backed up data in different location or medias, it mean if we kept our data in hard drive after some time we kept same data into another device. This system Rotating your data in different storage devices or medias

The goal of media rotation is to provide multiple copies of data, so that in case of a failure or loss of the primary backup, there are other copies of data that can be used for recovery.

Important of Media rotation :

1. We can recover data even primary copy is lost.
2. We can recover data from another devices due to disaster damaged of primary data.
3. Reduce risk of data corruption.

RAID System:

A **raid system** generally refers to a **Redundant Array of Independent Disks (RAID)**, a technology used in computing to combine multiple physical disk drives into a single logical unit. This configuration is aimed at improving performance, increasing storage capacity, and ensuring data redundancy. RAID systems are widely used in both personal computing and enterprise environments, particularly in scenarios where reliability, speed, and storage efficiency are crucial.

RAID level

A **RAID level** refers to a specific configuration of multiple disk drives that define how data is distributed, mirrored, or striped across the drives in an array. Each RAID level offers a different balance of performance, data redundancy, and storage capacity. Below are the most commonly used RAID levels:

1. RAID 0(Striping)

In this level Data is split across two or more drives. It will increase speeds as you're reading and writing from multiple disks at a time where all disk are perform parallely. But all data on all disks is lost if any one disk fails. The main purpose of RAID 0 is boost speed of R/W data.

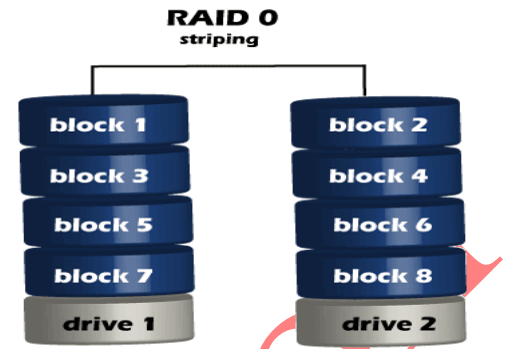

2. RAID 1 (Mirroring)

In this level Data is copied exactly to two or more drives (mirrored). If one drive fails, you still have an exact copy of your data on the other drive.

Pros: Excellent data protection (redundancy).

Cons: Storage capacity is halved because the same data is written to both drives.

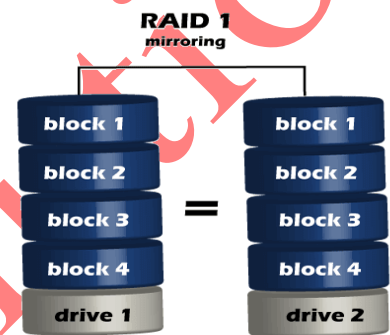

3. RAID 5 (Striping with single Parity):

RAID 5 requires the use of at least three drives. It combines these disks to protect data against loss of any one disk. It strips data across multiple drives to increase performance.

Pros: Good speed and data protection with more efficient storage than RAID

Cons: Slower write speeds due to parity calculations.

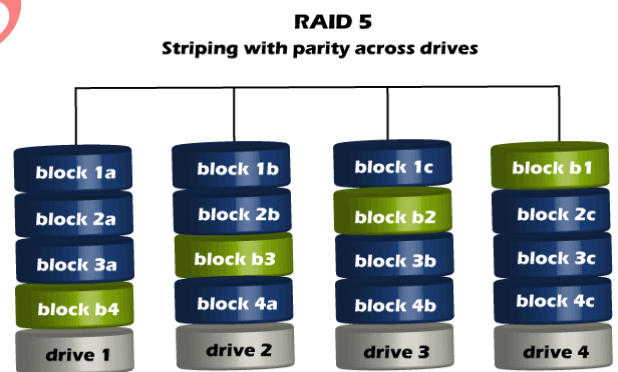

4. RAID 10 (1+0)

This level Combines RAID 1 and RAID 0 in a single system, which offers higher performance than RAID 1, but at a much higher cost. This is a nested or hybrid RAID configuration. It provides security by mirroring all data on secondary drives while using striping across each set of drives to speed up data transfers.

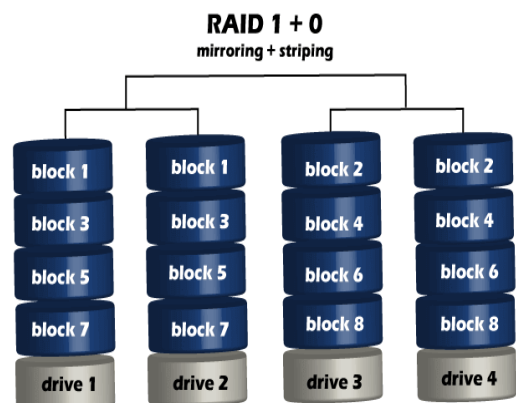

5. RAID 6

RAID 6 is a storage technique that uses block-level striping with double parity distributed across all disks. It provides high fault tolerance because it can continue to operate even if two hard disks fail at the same time. RAID 6 is commonly used in servers and data centers where data safety is very important.

Advantages :

RAID 6 can tolerate failure of any two disks without data loss.
Suitable for enterprise servers and critical data storage.

Disadvantages:

Writing data is slower due to double parity calculation.
Requires at least four disks and more storage space is used for parity.

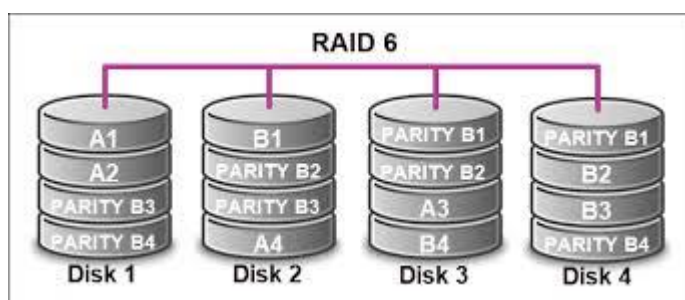

Recovery techniques

Recovery techniques in computers refer to the various methods used to restore data, repair systems, or recover from failures. These techniques help to fix issues that may arise due to hardware failure, software corruption, accidental data loss, or malware attacks. Below are some common recovery techniques in computer systems:

1. System Restore

System Restore allows users to return their computer to a previous working state by using restore points that Windows automatically creates or that the user manually sets. This technique helps fix problems caused by recent changes (like software installations or updates).

When software issues arise, such as after installing a problematic update or program, causing system instability or crashes we need to use system restore technique.

2. Data Backup and Restore

Regular backups are critical for data recovery. Backup solutions include full, incremental, or differential backups, often stored on external drives or cloud services. When data is lost or corrupted, backups can be restored to recover important files.

Common tools: Time Machine (macOS), Windows Backup, cloud services (Google Drive, OneDrive, Dropbox)

3. File Recovery Software

File recovery software can scan storage devices for deleted or lost files and attempt to recover them, even if they are no longer visible in the file system.

- **When to use:** When files are accidentally deleted, formatted, or become inaccessible due to corruption. **Common tools:** EaseUS Data Recovery Wizard, Disk Drill, PhotoRec.

4. Disk Repair Tools

Disk repair tools scan and fix errors in the file system or physical disk. These tools can correct problems like bad sectors or file system inconsistencies that prevent the system from booting or accessing files.

Common tools:

- CHKDSK** (Windows): Scans and repairs the file system and checks for bad sectors.
- fsck** (Linux): File system check and repair tool.
- Disk Utility** (macOS): Includes disk repair features.